



Congratulations on the purchase of your new VECO TV, Vizio's Eco-hugging system.

Your friends will be **green with envy** not only because of the superior quality of the look and performance, but also because it's **Earth-friendly**. How? It uses 44% less energy than most models, the packaging and this manual are made from recyclable material, this manual is printed with soy ink, and even the amount of paper this manual is normally printed on has been reduced.

We hope you will experience **many years of enjoyment** from your new VIZIO VECO TV. For assistance, please call (877) 698-4946 or e-mail us at techsupport@vizio.com. To purchase or inquire about accessories and installation services for your VIZIO HDTV, please visit our website at www.VIZIO.com or call toll free at 888-VIZIOCE (888-849-4623).

We recommend you register your VIZIO HDTV at our website www.VIZIO.com.

For peace of mind and to protect your investment beyond the standard warranty, VIZIO offers on-site extended warranty service plans. These plans give additional coverage during the standard warranty period. Visit our website or call us to purchase a plan.

Write down the serial number located on the back of your VIZIO HDTV for future reference.

Purchase Date _____



VIZIO is a registered trademark of VIZIO, Inc. dba V, Inc.
HDMI logo and "High Definition Multimedia Interface" are registered trademarks of HDMI Licensing LLC.

Manufactured under license from Dolby Laboratories.
Dolby and the double-D symbol are trademarks of Dolby Laboratories.

SRS is a trademark of SRS Labs, Inc. SRS technology is incorporated under license from SRS Labs, Inc.

THE TRADEMARKS SHOWN HEREIN ARE THE PROPERTY OF THEIR RESPECTIVE OWNERS; IMAGES USED ARE FOR ILLUSTRATION PURPOSES ONLY. BRAVO, VIZIO AND THE V LOGO AND WHERE VISION MEETS VALUE AND OTHER VIZIO TRADEMARKS ARE THE INTELLECTUAL PROPERTY OF VIZIO INC. PRODUCT SPECIFICATIONS ARE SUBJECT TO CHANGE WITHOUT NOTICE OR OBLIGATION. © 2008 VIZIO INC. ALL RIGHTS RESERVED.

Important Safety Instructions

Your HDTV is designed and manufactured to operate within defined design limits, and misuse may result in electric shock or fire. To prevent your HDTV from being damaged, the following rules should be observed for the installation, use, and maintenance of your HDTV. Read the following safety instructions before operating your HDTV. Keep these instructions in a safe place for future reference.

- To reduce the risk of electric shock or component damage, switch off the power before connecting other components to your HDTV.
- Unplug the power cord before cleaning your HDTV. Use only a damp cloth for cleaning your HDTV. Do not use any liquid, spray, or abrasive cleaners on your HDTV.
- Always use the accessories recommended by the manufacturer to insure compatibility.
- When moving your HDTV from an area of low temperature to an area of high temperature, condensation may form in the housing. Wait before turning on your HDTV to avoid causing fire, electric shock, or component damage.
- Use only with the cart, stand, tripod, bracket, or table specified by manufacturer or sold with your HDTV. When a cart is used, use caution when moving the cart/HDTV combination to avoid injury from tip-over. Do not place your HDTV on an unstable cart, stand, or table. If your HDTV falls, it can injure a person and cause serious damage to your HDTV.
- A distance of at least 3 feet should be maintained between your HDTV and any heat source, such as a radiator, heater, oven, amplifier, etc. Do not install or operating your HDTV close to smoke or moisture as it may cause fire or electric shock.
- Slots and openings in the back and bottom of the cabinet are provided for ventilation. To ensure reliable operation of your HDTV and to protect it from overheating, be sure these openings are not blocked or covered. Do not place your HDTV in a bookcase or cabinet unless proper ventilation is provided.
- Never push any object into the slots and openings on your HDTV cabinet. Do not place any objects on the top of your HDTV. Doing so could short circuit parts causing a fire or electric shock. Never spill liquids on your HDTV.
- Your HDTV should be operated only from the type of power source indicated on the label. If you are not sure of the type of power supplied to your home, consult your dealer or local power company.
- Do not apply pressure or throw objects at your HDTV. This may compromise the integrity of the display. The manufacturer's warranty does not cover user abuse or improper installations.
- The power cord must be replaced when using different voltage than the voltage specified. For more information, contact your dealer.
- Your HDTV is equipped with a **three-pronged grounded plug (a plug with a third grounding pin)**. This plug will fit only into a grounded power outlet. This is a safety feature. If your outlet does not accommodate the three-pronged plug, have an electrician install the correct outlet, or use an adapter to ground your HDTV safely.



- The lightning flash with arrowhead symbol within an equilateral triangle is intended to alert the user to the presence of un-isolated, dangerous voltage within the inside of your HDTV that may be of sufficient magnitude to

constitute a risk of electric shock to persons.

- The exclamation point within an equilateral triangle is intended to alert the user to the presence of important operating and servicing instructions in the literature accompanying your HDTV.



- Do not overload power strips and extension cords. Overloading can result

in fire or electric shock.

- The wall socket should be installed near your HDTV and easily accessible.
- Only power of the specified voltage can be used for your HDTV. Any other voltage than the specified voltage may cause fire or electric shock.
- Do not touch the power cord during lightning. To avoid electric shock, avoid handling the power cord during electrical storms.
- Unplug your HDTV during a lightning storm or when it will not be used for long periods of time. This will protect your HDTV from damage due to power surges.
- Do not attempt to repair or service your HDTV yourself. Opening or removing the back cover may expose you to high voltages, electric shock, and other hazards. If repair is required, contact your dealer and refer all servicing to qualified service personnel.
- Keep your HDTV away from moisture. Do not expose your HDTV to rain or moisture. If water penetrates into your HDTV, unplug the power cord and contact your dealer. Continuous use in this case may result in fire or electric shock.
- Do not use your HDTV if any abnormality occurs. If any smoke or odor becomes apparent, unplug the power cord and contact your dealer immediately. Do not try to repair your HDTV yourself.
- Avoid using dropped or damaged appliances. If your HDTV is dropped and the housing is damaged, the internal components may function abnormally. Unplug the power cord immediately and contact your dealer for repair. Continued use of your HDTV may cause fire or electric shock.
- Do not install your HDTV in an area with heavy dust or high humidity. Operating your HDTV in environments with heavy dust or high humidity may cause fire or electric shock.
- Follow instructions for moving your HDTV. Ensure that the power cord and any other cables are unplugged before moving your HDTV.
- When unplugging your HDTV, hold the power plug, not the cord. Pulling on the power cord may damage the wires inside the cord and cause fire or electric shock. When your HDTV will not be used for an extended period of time, unplug the power cord.
- To reduce risk of electric shock, do not touch the connector with wet hands.
- Insert batteries in accordance with instructions. Incorrect polarities may cause the batteries to leak which can damage the remote control or injure the operator.
- If any of the following occurs, contact the dealer:
 - The power cord fails or frays.
 - Liquid sprays or any object drops into your HDTV.
 - Your HDTV is exposed to rain or other moisture.
 - Your HDTV is dropped or damaged in any way.
 - The performance of your HDTV changes substantially.



Television Antenna Connection Protection

External Television Antenna Grounding

If an outside antenna/satellite dish or cable system is connected to your HDTV, make sure that the antenna or cable system is electrically grounded to provide some protection against voltage surges and static charges.

Article 810 of the National Electrical Code, ANSI/NFPA 70, provides information with regard to proper grounding of the mast and supporting structure, grounding of the lead-in wire to an antenna discharge unit, size of the grounding conductors, location of antenna discharge unit, connection to grounding electrodes, and requirements of the grounding electrode.

Lightning Protection

For added protection of your HDTV during a lightning storm or when it is left unattended or unused for long periods of time, unplug your HDTV from the wall outlet and disconnect the antenna or cable system.

Power Lines

Do not locate the antenna near overhead light or power circuits, or where it could fall into such power lines or circuits.

Remember, the screen of the coaxial cable is intended to be connected to earth in the building installation.

FCC Bulletin for New TV Owners

After February 17, 2009, a television receiver with only an analog broadcast tuner will require a converter box to receive full power over-the-air broadcasts with an antenna because of the Nation's transition to digital broadcasting. Analog-only TVs should continue to work as before to receive low power, Class A or translator television stations and with cable and satellite TV services, gaming consoles, VCRs, DVD players, and similar products.

Information about the DTV transition is available from <http://www.DTV.gov> or this manufacturer at 877 MY VIZIO (877-698-4946), and from <http://www.dtv2009.gov> or 1-888-DTV-2009 for information about subsidized coupons for digital-to-analog converter boxes.

Your HDTV comes with a built-in tuner capable of processing digital broadcasts, making it easier for you to receive this type of signal without the need of an extra converter box.

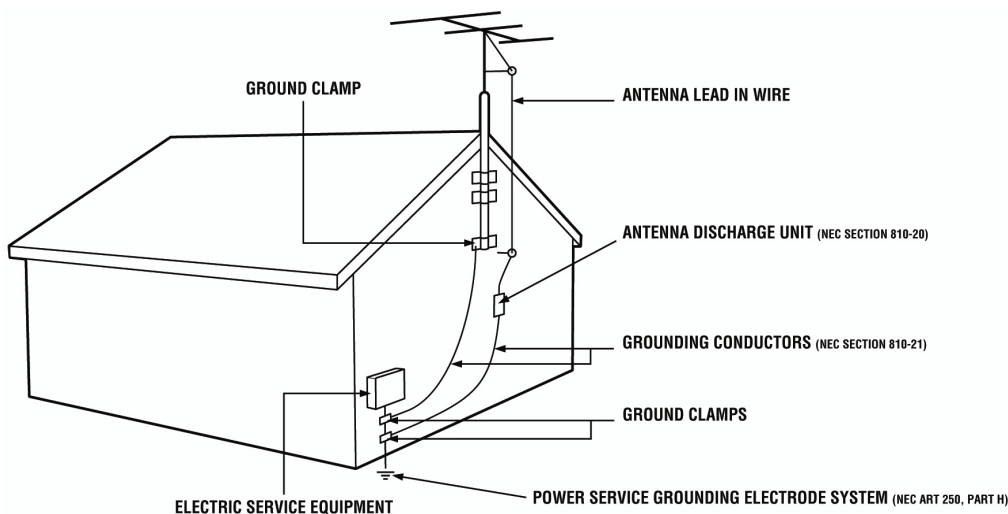

Table of Contents

FCC Bulletin for New TV Owners 3

Table of Contents4

Opening the Package5

Package Contents 5

TV Setup and Stand Assembly.....6

Understanding Basic Controls and Connections7

Front Bezel 7

Right Side Panel Controls 7

Rear Panel Connections..... 8

VIZIO Remote Control 9

Inserting the remote control batteries 10

Using a Cable or Satellite Remote 10

Setting up Your HDTV11

Wall Mounting your HDTV 11

Choosing a video connection12

Connecting Coaxial (RF) 13

 Using Your Antenna or Digital Cable for DTV /TV ... 13

 Using the Antenna or Cable through your VCR 13

Connecting Your HDTV Set-Top Box 14

 Using HDMI 14

 Connecting your HDTV Set-Top Box (Better): 15

 Using Component Video..... 15

Connecting Your Basic Set-Top Box 16

 Using Composite Video 16

 Using Coax (RF)..... 16

Connecting Your DVD Player 17

 Using HDMI 17

 For DVD Players with DVI: 17

 Using Component Video..... 18

 Using S-Video (AV) 18

Connecting an external Receiver/Amp 20

 Optical Output of Audio received with HD Programs 20

Connecting a PC Computer 21

 Preset PC Resolutions 22

 Using your HDTV the first time 23

 Selecting Inputs 25

 Fine-tuning the picture 25

 Using the Program Guide 26

 Displaying the Information Banner 26

 Using the On-Screen Display (OSD) 27

Advanced Settings 27

 Adjusting the Picture Settings 27

 Adjusting the Audio Settings 29

 Adjusting the TV settings 30

 Adjusting the Setup settings 31

 Adjusting the Parental Control settings 32

 Understanding Viewing Modes 34

 Normal Mode 34

 Panoramic Mode 34

Maintaining and Troubleshooting 35

 Maintenance 35

 Important..... 35

 Cleaning the Housing and Remote Control..... 35

 Cleaning the Screen 35

 Troubleshooting 36

 Telephone & Technical Support..... 37

Regulations and Specifications..... 38

 Compliance..... 38

 FCC Class B Radio Interference Statement 38

 Specifications 39

 Glossary – Standard Definitions 40

VIZIO LIMITED PRODUCT WARRANTY 41

VIZIO RETURN POLICY 42

 Warranty Replacement Procedure..... 43

 Mail-In Warranty Repair Procedure 43

Index..... 44



Opening the Package

Your HDTV and its accompanying accessories are carefully packed in a cardboard carton that has been designed to protect it from transportation damage. Once you have opened the carton, check that your HDTV is in good condition and that all of the contents are included.

The glass surface can easily be scratched or broken, so handle your HDTV gently and never place your HDTV with the glass facing downwards on a surface without protective padding.

IMPORTANT: Save the carton and packing material for future shipping.

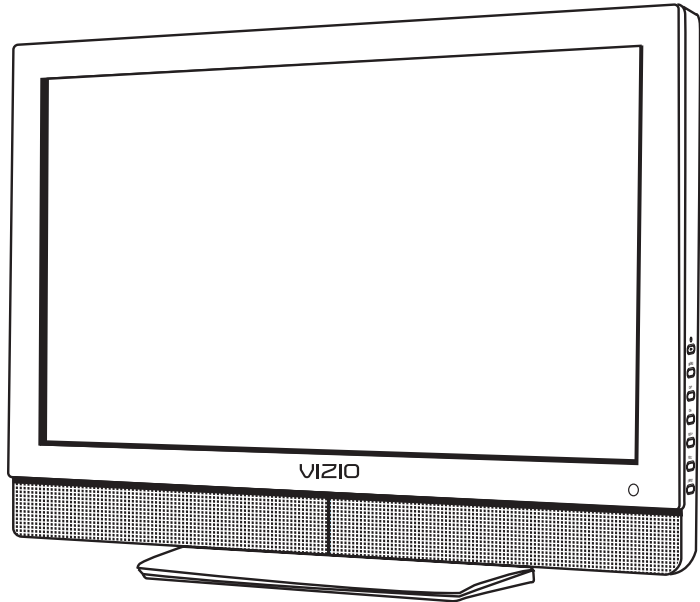

Package Contents

- VIZIO VECO320L1A HDTV
- VIZIO Remote Control VR2 (White)
- VIZIO Removable Stand and Instructions
- Power Cord
- This User Manual
- Quick Setup Guide
- 2 (Double A) Batteries for the Remote Control

Additional certified accessories for your HDTV are sold separately:

- Wall mounts
- High Definition cables
- Extra or replacement remote

VIZIO also offers installation services and extended warranty services for your HDTV.

To purchase or inquire about additional accessories and services for your VIZIO HDTV, visit our web site at www.VIZIO.com or call us toll free at 888-VIZIOCE (888-849-4623)

Caution: Do not apply pressure or throw objects at your HDTV. This may compromise the integrity of the display. The manufacturer's warranty does not cover user abuse or improper installations.



TV Setup and Stand Assembly

Note: We strongly recommend that two people perform the setup and assembly due to the weight and size of the TV.

To unpack the TV and stand base:

1. Remove the remote control, batteries, and power cord from the foam end caps.
2. Remove the two top foam end caps.
3. Remove the stand base under foam end cap.
4. Remove the TV from the box and lay it face down on a clean, flat surface.

Note: Make sure that the surface is free of debris to prevent the TV screen from getting scratched.

To attach the TV stand base:

1. Line up the arrows on the stand neck (attached to the TV) with the arrows on the stand base.
2. Push the stand base onto the stand neck.
3. On the bottom of the base, insert the four included screws and tighten.
4. Move the TV into an upright position.

Stand Neck

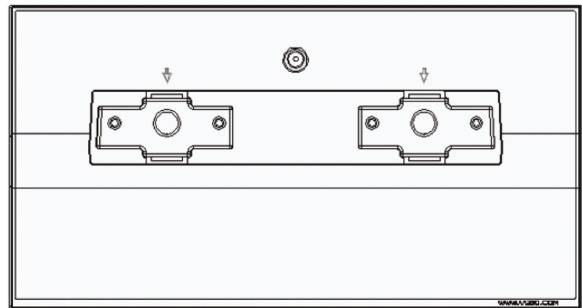

Stand Base



Understanding Basic Controls and Connections

Front Bezel

1) POWER INDICATOR (VIZIO logo):

- White: On
- Orange: Standby

2) REMOTE CONTROL SENSOR:

- Point the remote control directly at the sensor for the best response.

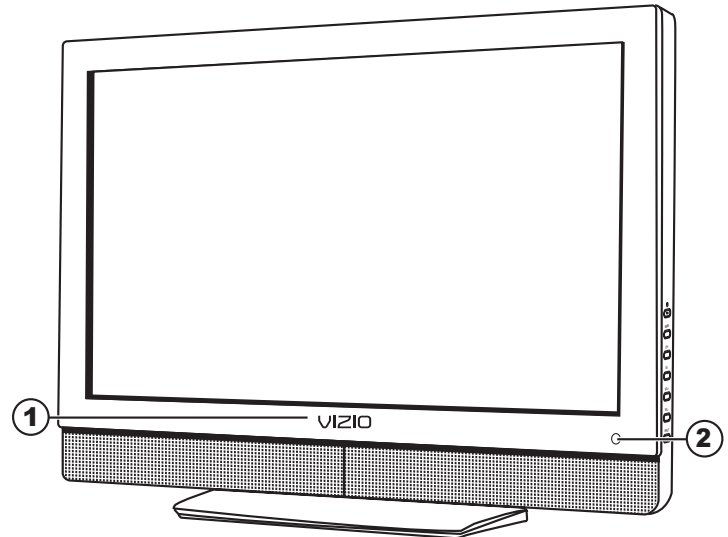

Right Side Panel Controls

POWER (⏻)

- Turns your HDTV ON and OFF.

MENU

- Activates the On-Screen Display (OSD).
- If a sub-menu is active, pressing MENU will proceed to the next screen (same as ENTER function on the remote).

CHANNEL + / -

- Steps up or down through the TV channels.
- Moves up and down through controls in the OSD menus.

VOLUME + / -

- Increases or decreases the speaker volume.
- Moves left and right in the OSD menus.

INPUT

- Press repeatedly to cycle through the video inputs.
- If a sub-menu is active, returns to the previous menu level.

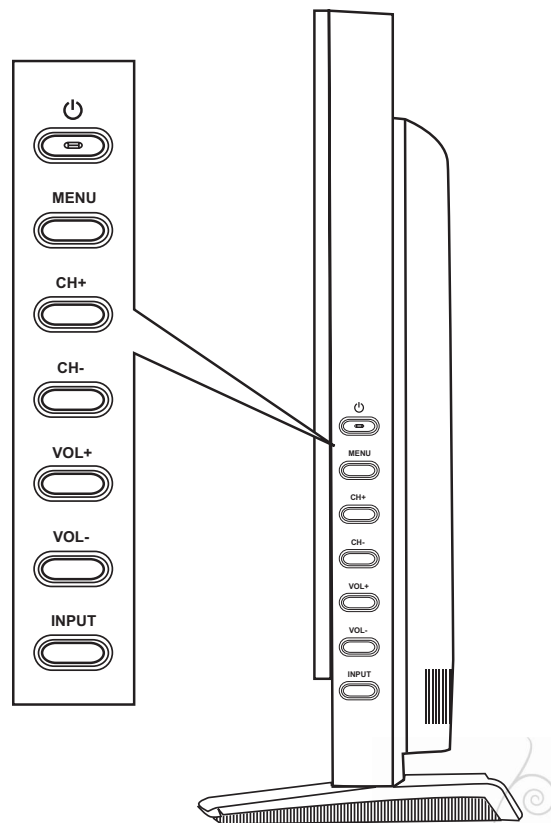

Rear Panel Connections

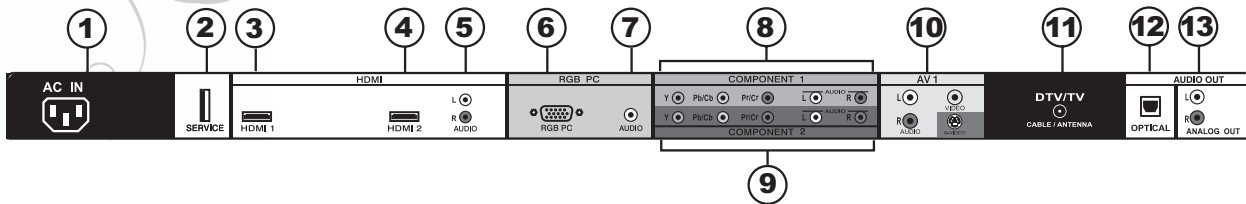

No.	Connection	Rear Panel Color Code	Description
1	AC IN	Black	Connect the supplied AC power cord.
2	SERVICE	White	For factory service only. Use of this input for any purpose other than factory authorized service will void the manufacturer's warranty of this equipment.
3	HDMI 1	White	Connect the primary source for digital video such as a DVD multimedia player or set-top box.
4	HDMI 2	White	Connect a secondary source for digital video such as a DVD multimedia player or set-top box. To use to a DVI enabled device, connect a DVI-HDMI cable here and connect the analog audio output of the device to the L+R HDMI Audio ports. VIZIO Certified HDMI and HDMI-DVI cables are available for purchase from www.VIZIO.com or by calling 888-VIZIOCE (888-849-4623).
5	HDMI Audio	White	Connect the analog audio output of a device to the L+R AUDIO here when using a DVI enabled device that is connected to the HDMI2 port.
6	RGB PC	Blue	Connect the video from a computer here.
7	PC Audio	Blue	Connect the audio (1/8 in. mini plug stereo connector) from a computer here.
8	COMPONENT 1 (YPb/CbPr/Cr with Audio L/R)	Green	Connect your primary source component (like a DVD Player or set top box) here. From left to right, use green for Y, blue for Pb (or Cb), and red for Pr (or Cr) inputs. Use white for left audio and red for right audio.
9	COMPONENT 2 (YPb/CbPr/Cr with Audio L/R)	Purple	Connect your secondary source (like a DVD Player or set top box) here. From left to right, use green for Y, blue for Pb (or Cb), and red for Pr (or Cr) inputs. Use white for left audio and red for right audio.
10	AV1/S-Video	Yellow and Red	Connect a source for composite (like a VCR or video game). Use the white and red connectors to connect the external audio from the same source. The S-Video, if connected will take priority over the video of the RCA connector. The audio connectors (white and red) need to be connected in order to hear the program.
11	DTV/TV (Cable/Antenna)	Black	Connect to an antenna or digital cable for digital TV. For digital TV stations in your area visit www.antennaweb.org .
12	OPTICAL	White	Connect an SPDIF Optical cable from your HDTV to your home theater system to play digital audio through your home speakers.
13	AUDIO OUT	White	Connect the audio from the HDTV to an external device (like a home theatre system, external amplifier, or stereo.)



VIZIO Remote Control

() **POWER** – Press to turn your HDTV ON. Press it again to turn it OFF.

GUIDE – Press to display program information.





TV – Press to select TV.

AV – Press to select the Audio Video input. Press repeatedly to go to the AV input. Note: If the S-Video cable is being used, the AV will show the signal going through this input because the S-Video takes priority.

COMP – Press to select Component (YPbPr) input. Press repeatedly to go through the Component (1 & 2) inputs.



HDMI – Press to select HDMI input. Press repeatedly to go through the HDMI (1 & 2) inputs.



MENU – Press to launch the On-Screen Display (OSD) menu.

Arrow Buttons (   ) – After pressing **MENU**, use arrow buttons to navigate through the OSDs and adjust options, then press **LAST** to select your chosen option.

MUTE – Press to turn the sound on and off.

LAST – Press to recall the previously viewed channel.

VOL ( or ) – Press to increase or decrease the speaker volume.

CH ( or ) – Press to step up or down through the TV channels.

NUMBER PAD – Press to select a channel or enter a password.

INPUT – Press repeatedly to cycle through the video inputs.

– (**Dash**) – In DTV mode (antenna), use this button to access digital sub-channels. For example, to select 28-2, press 2, press 8, press the dash, and then press 2.

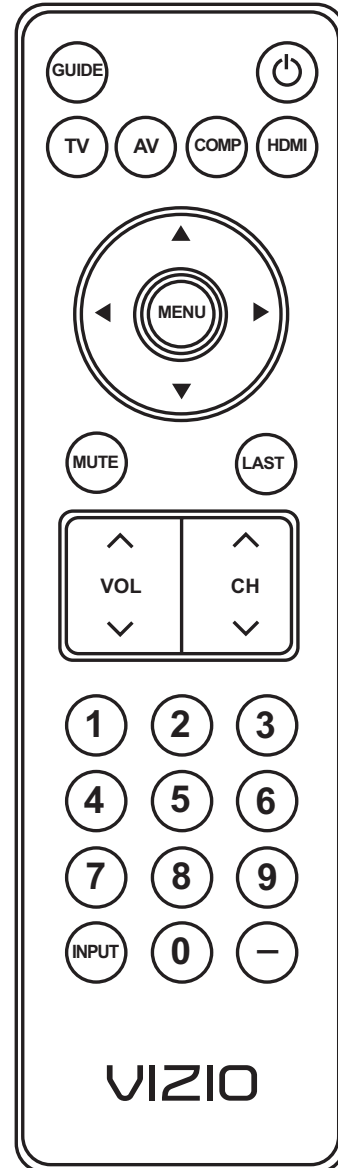

Remote Control Range

- The effective range of the remote control is approximately 30 feet (10 meters) from the front of the receiver window and 13 feet (4 meters) when 30° to the left and right, 20° up and down.
- Point the remote control at the remote control sensor on the front of your HDTV to send commands.
- Do not place any obstacles between the remote control and the remote control sensor.

VIZIO Remote Control Precautions

- Keep the remote dry and away from heat sources and humidity.
- If your HDTV responds erratically to the remote control or does not respond at all, check the batteries. If the batteries are low or exhausted, replace them with fresh batteries.
- When not using the remote control for a long period of time, remove the batteries.
- Do not take the batteries apart, heat them, or throw them into a fire.
- Do not subject the remote control to undue physical stress, such as striking or dropping it.
- Do not attempt to clean the remote control with a volatile solvent. Wipe it with a clean, damp cloth.
- Do not mix old and new batteries or different types of batteries.

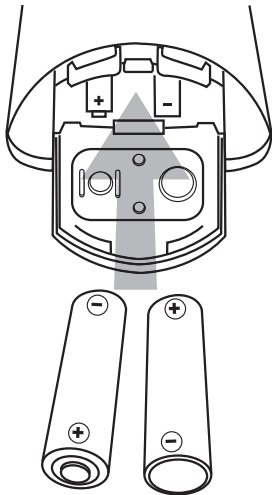

Inserting the remote control batteries

1. Remove the battery cover on the back of the remote control.
2. Insert two AA batteries (included) into the remote control, making sure you match the (+) and (-) symbols on the batteries with the (+) and (-) symbols inside the battery compartment.
3. Re-attach the battery compartment cover.

Precautionary Tips for Inserting the Batteries:

- Only use the specified AA batteries.
- Do not mix new and old batteries. This may result in cracking or leakage that may pose a fire risk or lead to personal injury.
- Inserting the batteries incorrectly may also result in cracking or leakage that may pose a fire risk or lead to personal injury.
- Dispose of the batteries in accordance with local laws and regulations.
- Keep the batteries away from children and pets.

Using a Cable or Satellite Remote

Your VIZIO remote uses codes 11758 and 10178 to work your LCD HDTV. To use a cable or satellite remote to work the LCD HDTV, refer to your cable or satellite remote user guide for more information on how to program the remote. If your cable or satellite remote uses a 5-digit code (like most Direct TV units), first try 11758 and then, if that does not work, 10178. If your cable or satellite remote uses a 4-digit code, try 1758 and then 0178 as an alternative. If your cable or satellite remote uses a 3-digit code (EchoStar or Dish Network for example), use code 627.

Note: Some buttons may not function as expected on your cable or satellite remote. Typically power, volume and mute will work.



Setting up Your HDTV

- Read this user manual carefully before installing your HDTV.
- The average power consumption of your HDTV is 84W. Use the included power cord. When an extension cord is required, use one with the correct power rating. The cord must be grounded and the grounding feature must not be compromised.
- Your HDTV should be installed on a flat surface to avoid tipping.
- For proper ventilation, you must allow space between the back of your HDTV and the wall.
- If you want to mount your HDTV on the wall, see *Wall Mounting your HDTV* for additional information.
- Avoid installing your HDTV in places with high humidity, dust, or smoke so you do not shorten the service life of the electronic components.
- Install your HDTV in a level, landscape orientation, with the VIZIO logo at the bottom to prevent poor ventilation and excessive component damage.

VIZIO offers professional installation services. Contact VIZIO for more information on these services at 888-VIZIOCE (888-849-4623) or www.VIZIO.com.

Wall Mounting your HDTV

Your HDTV can be mounted on the wall for viewing. If you choose to mount your HDTV on the wall, follow the instructions below.

1. Remove the base:

- Disconnect the cables from your HDTV.
- Place your HDTV face down on a soft, flat surface to prevent damage to the screen.
- Remove the eight (8) screws holding the base to the TV.
- Remove the stand base.

2. Mount your HDTV on the wall:

- Attach your HDTV to a wall mount (sold separately) using the mounting holes in the back panel of your HDTV. Read the instructions that came with your specific wall mount to properly hang your HDTV.

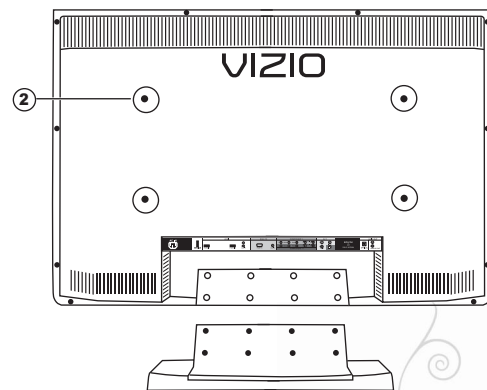
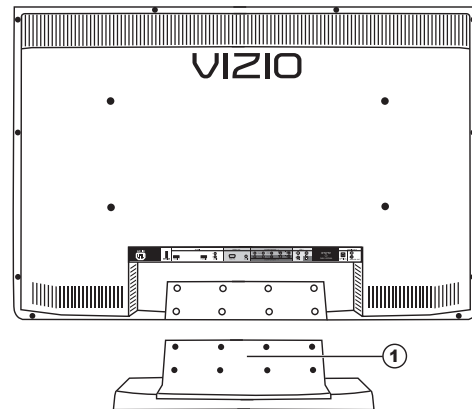







Additional Information:

Mounting hole pitch	420mm horizontally x 200mm vertically
Screw type	Metric M8 1.25mm pitch
Screw length	Depends on the thickness of the wall mount plate. VIZIO brackets come with different length screws.

To find the perfect mount for your HDTV, browse VIZIO's certified wall mount selection at www.VIZIO.com or call 888-VIZIOCE (888-849-4623).

Choosing a video connection

Your HDTV has six different ways to connect your video equipment from a basic connection to the most advanced for digital displays.

Connection Quality (type)	Connector	Rear Panel Color Code	Description
Best (digital)		White	HDMI (High-Definition Multimedia Interface). HDMI is the first and only industry-supported, uncompressed, all-digital audio/video interface. HDMI connects an AV device (such as a set-top box, DVD player, or A/V receiver) to your HDTV using one cable to carry both the audio and video.
Best (digital) ----- Good (analog)		Black	DTV Coaxial RF. For digital programming, this input takes advantage of high-definition content. ----- TV Coaxial RF. The connection for standard NTSC TV using antenna or cable.
Best (analog)		Blue	RGB PC (VGA). When connecting a computer, this is most commonly used connection.
Better (analog)		Green and Purple	Component. The video signal is separated into three signals, one containing the black-and-white information and the other two containing the color information. This enhancement over S-Video takes advantage of the superior picture provided by progressive scan DVD players and HDTV formats.
Good (analog)		Red	S-Video. The video signal is separated into two signals, one containing the black-and-white information and the other containing the color information. Separating the color in this way avoids <i>cross color</i> effects where closely spaced black and white lines are erroneously displayed in color. It also enables text to be displayed more sharply.
Good (analog)		Yellow	Composite. The video signal is carried through the yellow jack and the audio is carried through the white and red jacks. This is the most commonly used video connection.

NOTE: For more information refer to the Quick Start Guide.



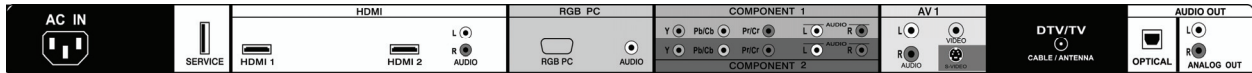

Connecting Coaxial (RF)

Using Your Antenna or Digital Cable for DTV /TV

1. Turn off the power to the HDTV.
2. Connect the coaxial (RF) connector from your antenna or digital cable (out-of-the-wall, not from the Cable Box) to the DTV/TV CABLE/ANTENNA connector.
3. Turn on the power to the HDTV.
4. Select DTV using the **INPUT** button on the remote or side of your HDTV, or by pressing the **TV** button on the remote control.

Note: Not all digital TV broadcasts are High Definition (HD). Refer to the program guides, or consult your cable, satellite or TV station operator. Digital broadcasts are not available in all areas. Refer to www.antennaweb.org for detailed information. Make sure the antenna and coaxial cable are correctly grounded. For Professional antenna installation contact us at www.VIZIO.com or call 1-888-VIZIOCE (1-888-849-4623).

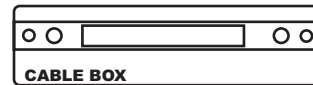
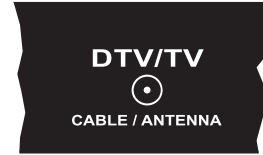

Using the Antenna or Cable through your VCR

1. Turn off the power to the HDTV and VCR.
2. Connect the "Output to TV", "RF Out" or "Antenna Out" connector on the rear of your VCR to the DTV/TV CABLE/ANTENNA connector at the rear of the High Definition TV.
3. Turn on the power to the HDTV and VCR.
4. Select TV using the **INPUT** button on the remote or on the side of your HDTV, or by pressing the **TV** button on the remote control.

Note: If you have an off-air antenna or cable TV, connect it to the "Antenna In" connector on the rear of your VCR.



Note: The HDMI input on the HDTV supports High-bandwidth Digital Content Protection (HDCP). HDCP encrypts the transmission between the video source and the digital display for added security and protection. Refer to your HDTV Set-Top Box user manual for more information about the video output requirements of the product or consult your cable or satellite operator.

Connecting Your HDTV Set-Top Box

Using HDMI

HDTV Set-Top Boxes that have a HDMI digital interface should be connected to the HDMI input of the LCD HDTV for optimal results.

Note: To maintain the display quality, use a VIZIO certified HDMI cable. Length is available up to 10 meters. See www.VIZIO.com or call 1-888-VIZIOCE (1-888-849-4623) for details.

Connecting your HDTV Set-Top Box (Best):

1. Turn off the power to the HDTV and HDTV Set-Top Box.
2. Connect a HDMI cable to the HDMI output of your HDTV Set-Top Box and the other end to the HDMI Input (white color area) at the rear of the High Definition TV.
3. Turn on the power to the HDTV and HDTV Set-Top Box.
4. Select HDMI 1 using the **INPUT** button on the remote or on the side of your HDTV, or by pressing the **HDMI** button on the remote control.
5. If HDMI 1 is being used, use HDMI 2 as the input and follow steps 1 through 3; and then select HDMI 2 in step 4.

For HDTV Set-Top Boxes with DVI:

1. Turn off the power to the HDTV and HDTV Set-Top Box.
2. Using a HDMI-DVI cable, connect the DVI end to your HDTV Set-Top Box and the HDMI end to the HDMI Input (white color area) at the rear of the High Definition TV.
3. Using an audio cable (white and red connectors), connect the cable to the audio output connectors associated with the DVI output on your HDTV Set-Top Box and connect the other end to the audio connectors associated with the HDMI input (white area) at the rear of the High Definition TV.
4. Turn on the power to the HDTV and HDTV Set-Top Box.
5. Select HDMI using the **INPUT** button on the remote or on the side of your HDTV, or by pressing the **HDMI** button on the remote control.

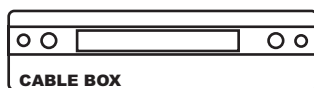
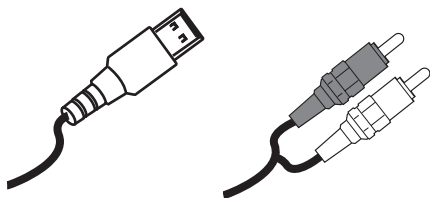
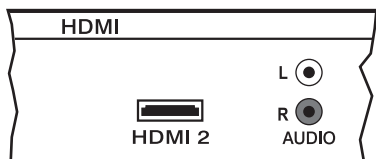
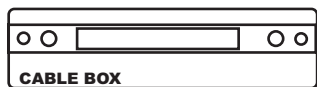
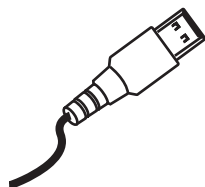
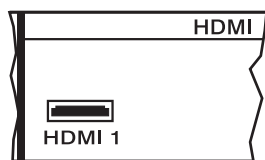

Connecting your HDTV Set-Top Box (Better):**Using Component Video**

1. Turn off the power to the HDTV and HDTV Set-Top Box.
2. Connect the Y (green color) connector on your HDTV Set-Top Box to the corresponding Y (green color) connector in the Component 1 group (green area on back of your HDTV).
3. Connect the Pb (blue color) connector on your HDTV Set-Top Box to the corresponding Pb (blue color) connector in the Component 1 group.
4. Connect the Pr (red color) connector on your HDTV Set-Top Box to the corresponding Pr (red color) connector in the Component 1 group.
5. Using an audio cable (white and red connectors), connect the cable to the audio output connectors associated with the Component output on your HDTV Set-Top Box and connect the other end to the audio connectors associated with the Component 1 group.
6. Turn on the power to the HDTV and HDTV Set-Top Box.
7. Select Component 1 using the **INPUT** button on the remote or on the side of your HDTV, or by pressing the **COMP** button on the remote control.
8. If Component 1 input is being used, use Component 2 as the input and follow the steps 1 through 6; and then select Component 2 in step 7.

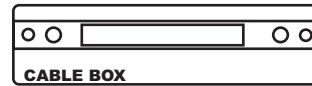
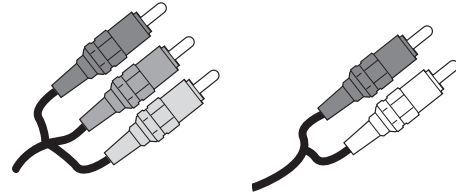
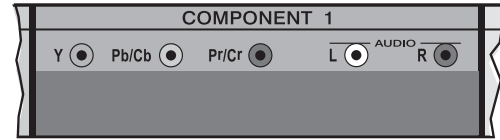

Note: Refer to your HDTV Set-Top Box user manual for more information about the video output requirements of the product or consult your cable or satellite operator.



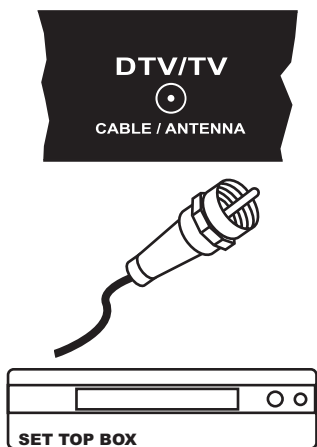
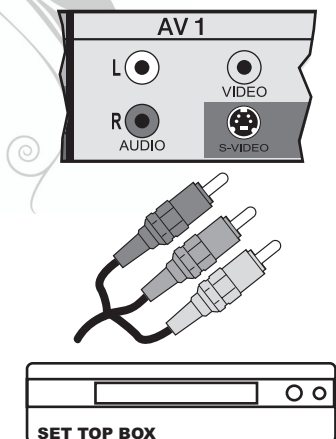

Connecting Your Basic Set-Top Box

Using Composite Video

1. Turn off the power to the HDTV and Set-Top Box.
2. Using the AV Cable, connect the Video (yellow color) connector on your Set-Top Box to the corresponding Video port (yellow area on the back of your HDTV).
3. Using the white and red connectors, connect the cable to the audio output connectors associated with the Video output on your Set-Top Box and connect the other end to the L/R audio connectors for the AV1 input.
4. Turn on the power to the TV and Set-Top Box.
5. Select AV using the **INPUT** button on the remote or on the side of your HDTV, or by pressing the **AV** button on the remote control.

Using Coax (RF)

1. Turn off the power to the HDTV and Set-Top Box.
2. Using a Coax (RF) cable, connect one end to the TV OUT (RF) on your Set Top Box and the other end to the DTV/TV input at the rear of the High Definition TV.
3. Turn on the power to the HDTV and Set-Top Box.
4. Select TV using the **INPUT** button on the remote or on the side of your HDTV, or by pressing the **TV** button on the remote control.

Note: Refer to your Set Top Box user manual for more information about selecting the video or RF output of the product.



Connecting Your DVD Player

You have several options for connecting your DVD player to your HDTV: HDMI, Component, AV (S-Video or Composite) inputs. Based on your configuration, you can decide which option is right for you.

Using HDMI

DVD players that have a digital interface such as HDMI (High Definition Multimedia Interface) should be connected to the HDMI input for optimal results.

Note: To maintain the display quality, use a VIZIO certified HDMI cable available up to 10 meters. See www.VIZIO.com or call 1-888-VIZIOCE (1-888-849-4623) for details.

Connecting your DVD Player (Best):

1. Turn off the power to the High Definition TV and DVD player.
2. Connect a HDMI cable to the HDMI output of your DVD player and the other end to the HDMI Input (white color area) at the rear of the HDTV.
3. Turn on the power to the High Definition TV and DVD player.
4. Select HDMI 1 using the **INPUT** button on the remote or on the side of your HDTV, or by pressing the **HDMI** button on the remote control.
5. If HDMI 1 is being used, connect to HDMI 2 as the input and follow steps 1 through 3; then select HDMI 2 in step 4.

For DVD Players with DVI:

1. Turn off the power to the High Definition TV and DVD player.
2. Using a HDMI-DVI cable, connect the DVI end to your DVD player and the HDMI end to the HDMI Input (white color area) at the rear of the HDTV.
3. Connect an audio cable (white and red connectors) to the audio output connectors associated with the DVI output of the DVD player and connect the other end to the audio connectors by the HDMI input (white area on the back of your HDTV).
4. Turn on the power to the HDTV and your DVD player.

Select HDMI 2 using the **INPUT** button on the remote or on the side of your HDTV, or by pressing the **HDMI** button on the remote control.

Note: Refer to your DVD player user manual for more information about the video output requirements of the product.

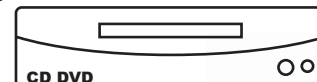
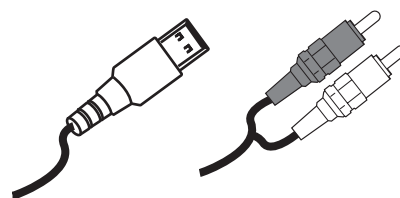
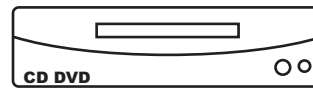
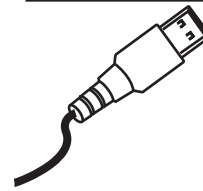
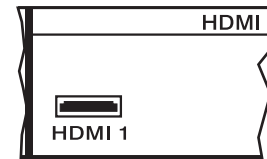

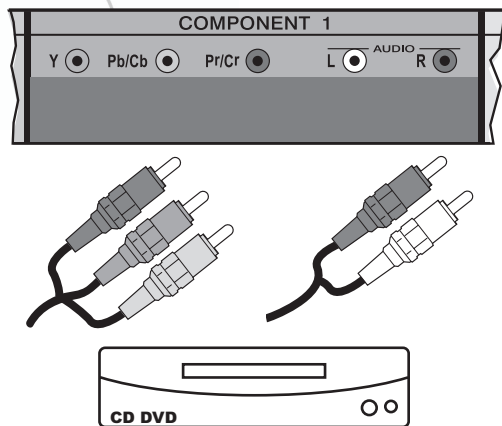

Connecting your DVD Player (Better):

Using Component Video

1. Turn off the power to the HDTV and DVD player.
2. Connect the Y (green color) connector on your DVD player to the corresponding Y (green color) connector in the Component 1 group (green area on the back of your HDTV).
3. Connect the Pb (blue color) connector on your DVD player to the corresponding Pb (blue color) connector in the Component 1 group.
4. Connect the Pr (red color) connector on your DVD player to the corresponding Pr (red color) connector in the Component 1.
5. Using an audio cable (white and red connectors), connect the cable to the audio output connectors associated with the Component output on your DVD player and connect the other end to the audio connectors associated with the Component 1 ports.
6. Turn on the power to the HDTV and DVD player.
7. Select Component 1 using the **INPUT** button on the remote or on the side of your HDTV, or by pressing the **COMP** button on the remote control.
8. If Component 1 input is being used, use Component 2 as the input and follow the steps 1 through 6; then select Component 2 in step 7.

Note: Refer to your DVD player user manual for more information about the video output requirements of the product.

Connecting your DVD Player (Good):

Using S-Video (AV)

1. Turn off the power to the HDTV and DVD player.
2. Connect the S-Video jack on the rear of your DVD player to the S-Video jack in the AV1 group (yellow/red area on the back of your HDTV).
3. Connect an audio cable (white and red connectors) to the audio output connectors associated with the S-Video output on your DVD player and connect the other end to the audio connectors associated with the AV1/S-VIDEO input on your HDTV.
4. Turn on the power to the HDTV and DVD player.
5. Select AV using the **INPUT** button on the remote or on the side of your HDTV, or by pressing the **AV** button on the remote control.

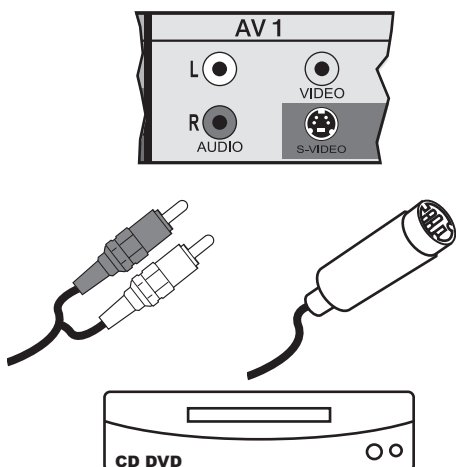

Connecting your DVD Player (Good)

1. Turn off the power to the HDTV and DVD player.
2. Connect the Video (yellow color) connector on your DVD player to the Video (yellow color) connector in the AV1 group (yellow/red color area on the back of your HDTV).
3. Connect the R (red color) and L (white color) audio connectors on your DVD player to the corresponding R (red color) and L (white color) audio input connectors in the AV1 group.
4. Turn on the power to the HDTV and DVD Player.
5. Select AV using the **INPUT** button on the remote or on the side of your HDTV, or by pressing the **AV** button on the remote control.

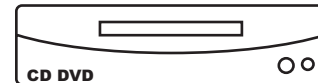
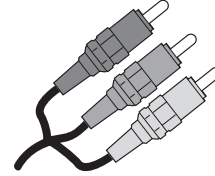
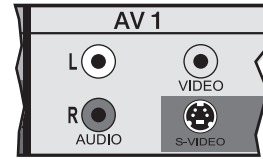

Note: Refer to your DVD player user manual for more information about the video output requirements of the product.

Connecting Your VCR or Video Camera

1. Turn off the HDTV and VCR or Video Camera.
2. Connect the S-Video jack on the rear of your VCR or Video Camera to the S-Video jack in the AV1 group (in the red area on the back of your HDTV).
3. Connect an audio cable (white and red connectors) cable to the audio output connectors associated with the S-Video output on your VCR or Video Camera and connect the other end to the audio connectors associated with the AV1 input on the HDTV.
4. Turn on the power to the HDTV and VCR or Video Camera.
5. Select AV using the **INPUT** button on the remote or on the side of your HDTV, or by pressing the **AV** button on the remote control.

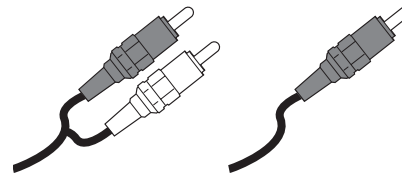
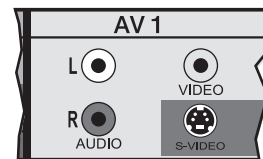

Note: Refer to your DVD player user manual for more information about the video output requirements of the product.



Connecting an external Receiver/Amp

Optical Output of Audio received with HD Programs

If your sound system has an SPDIF (optical) digital audio input you can connect it to the optical AUDIO OUT (white area on the back or your HDTV). This is active when receiving audio with the program being viewed no matter what input is being used.

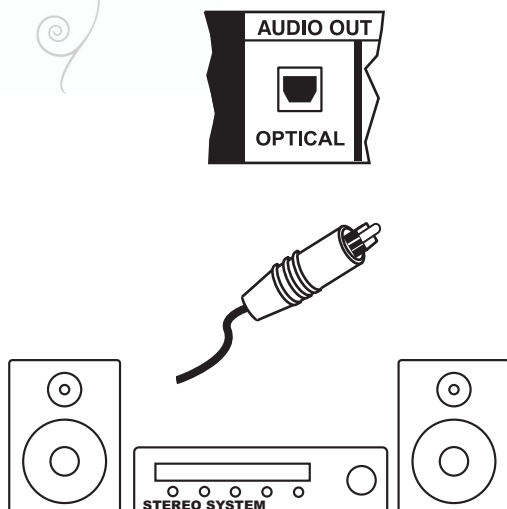

1. Turn off the power to the LCD HDTV and Receiver/Amp.
2. Using an audio cable (optical cable), connect the cable to the audio input connector on the Receiver/Amp and connect the other end to the OPTICAL OUT (white area) audio connector at the rear of the LCD HDTV.
3. Turn on the power to the LCD HDTV and Receiver/Amp.
4. Then press the **MENU** button on the remote control to open the On-Screen Display (OSD) menu.
5. Press the **▶** on the remote control to select the Audio menu.
6. Press the **▼** on the remote control to select **SPEAKERS**.
7. Press the **▶** on the remote control to select **OFF** so that the sound from the HDTV will now be routed through your Receiver/Amp system.

Press the **LAST** key once to return to the previous screen or repeatedly to return to your program if task has been completed.

Note:

Refer to your Receiver/Amp user manual to select the corresponding audio input.

The audio output can not be connected directly to external speakers.



Connecting a PC Computer

1. Turn off the power to the HDTV and PC Computer.
2. Connect a 15-pin D-Sub RGB (VGA) cable to the RGB output of your pc computer and the other end to the RGB PC input (blue area on the back of your HDTV).
3. Connect the Audio Out on your pc computer to the RGB PC Audio input (blue area on the back of your HDTV). This connection will require an 1/8" stereo mini plug.
4. Turn on the HDTV and PC Computer.
5. Select RGB using the **INPUT** button on the remote control or on the side of your HDTV.

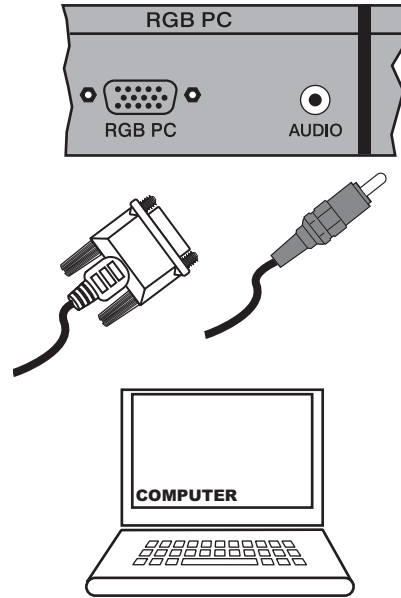

Note:

For the best picture quality when connecting a pc computer through RGB PC, set your pc computer timing mode to VESA 1366 x 768 at 60Hz. Please refer to the pc or graphic card's user guide for additional information on how to set the timing mode and the video output requirements of the product.

A RGB (VGA) cable and stereo mini jack cable are not included and can be purchased at an electronics store.



Preset PC Resolutions

If connecting to a PC through the RGB PC input, set the TV timing mode to VESA 1366x768 at 60Hz for best picture quality (refer to the graphic card's user guide for questions on how to set this timing mode). Please see the table below for the factory preset resolutions.

Resolution	Refresh (Hz)	H.Freq (kHz)	V.Freq (Hz)	H.Sync	V.Sync	Pixel Freq (MHz)
640x480	60	31.47	59.94	N	N	25.18
640x480	75	37.50	75.00	N	N	31.50
720x400	70	31.46	70.08	N	P	28.32
800x600	60	37.88	60.32	P	P	40.00
800x600	72	48.08	72.19	P	P	50.00
800x600	75	46.88	75.00	P	P	49.50
1024x768	60	48.36	60.00	N	N	65.00
1024x768	70	56.48	70.07	N	N	75.00
1024x768	75	60.02	75.03	P	P	78.75
*1366X768	60	47.55	59.81	P	P	85.50

NOTES: N = Negative, P = Positive, * = Primary Mode



Using your HDTV the first time

- 1. Connect Audio and Video Cables**
 Connect audio and video cables from the desired components to your HDTV as described in "Connecting Devices."
- 2. Connecting the Power Cable**
 Connect one end of the power cord to the power cord connector on the back of your HDTV. Then connect the other end into a power outlet.
- 3. Turning Power On**
 Press  on the remote control to turn on your HDTV.
- 4. Initial Setup**
 Press **TV** on the remote control. The *Initial Setup* screen comes up. Press the **▶** button.
- The *Language* screen opens. Press **▲** or **▼** to select your language, then press **▶**.
- The *Mode Setting* screen opens. Select between **Home Mode** and **Retail Mode**, selecting Home Mode will give you an opportunity to save energy. Press the **▶** button. If Retail Mode is selected by mistake; the next option will allow you to switch your selection back to Home Mode.
- If you are using a cable or satellite set-top box, your setup is complete. Press **LAST** to skip to the remaining steps. If you are NOT using a cable or satellite set-top box, continue with Step 8.

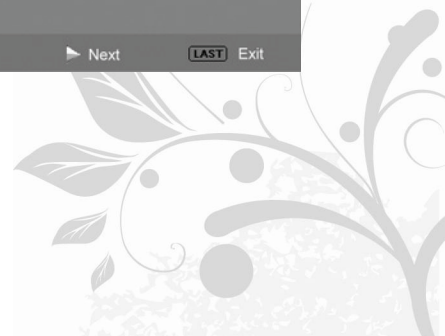
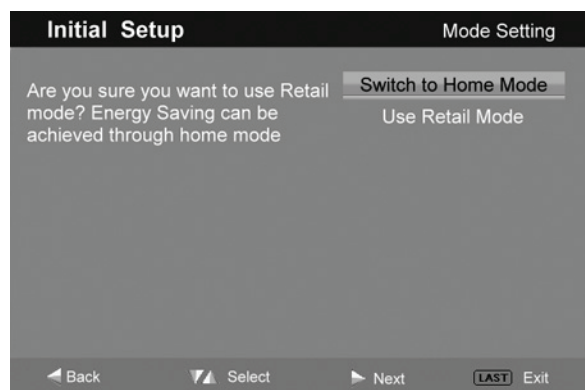
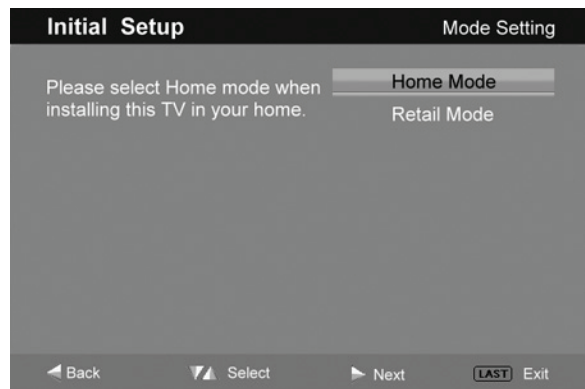
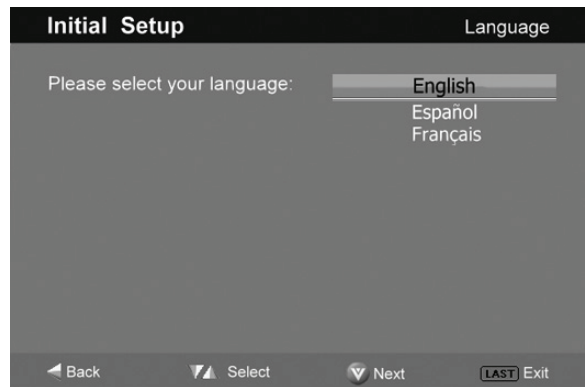
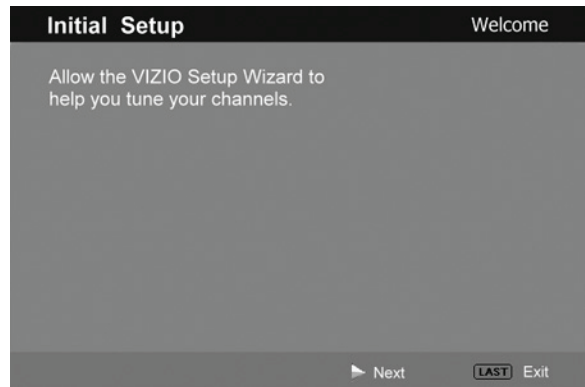

8. Press ▲ or ▼ to select your input source (Antenna or Cable), then press ►. The *Channel Scan* screen opens.

NOTE: Select Cable only if you receive your cable service without a set-top box.

9. Press ▲ or ▼ to select the desired channel scan process, then press ►. The *Channel Scan progress* screen opens if you selected *Scan*. Otherwise the *Complete* screen opens.

10. When the *Complete* screen opens, press ► to exit.

NOTE: DTV digital broadcast is not available in all areas. Refer to www.antennaweb.org to get information about availability in your area, antenna types, and in which direction to point your antenna. The channel availability through cable depends on which channels your cable operator supplies in Clear QAM. Consult your cable operator for more information.

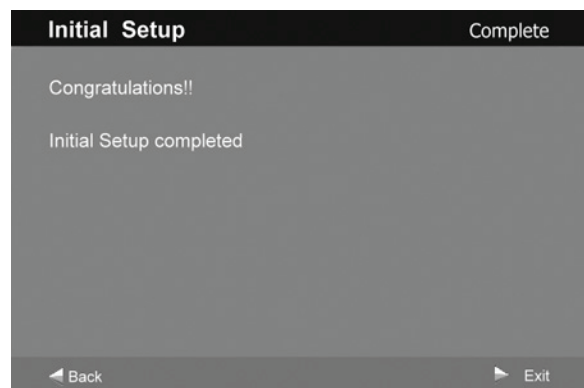
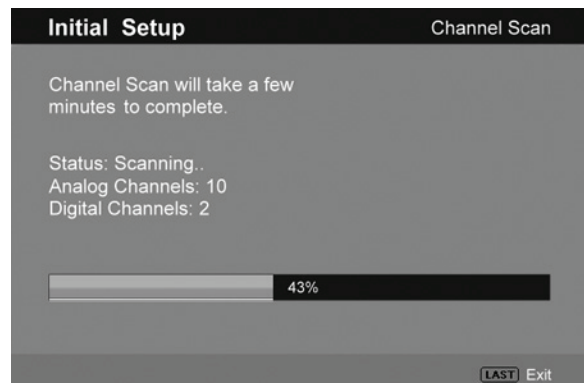
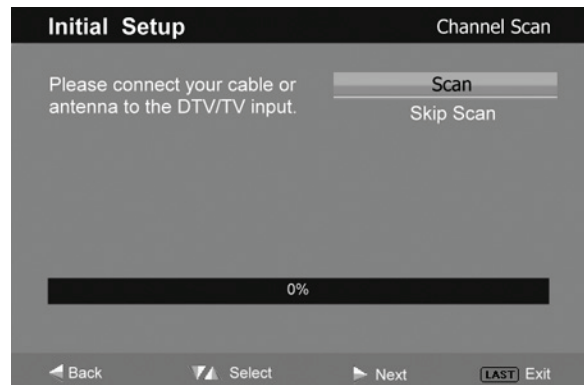
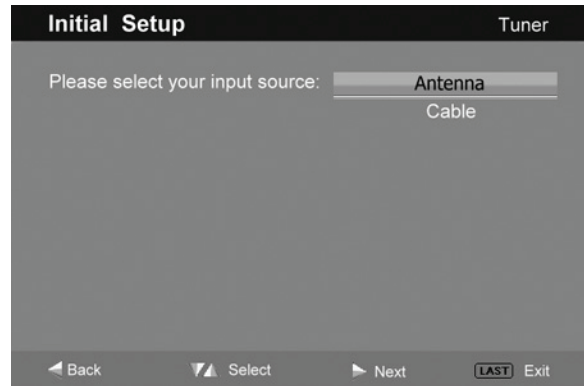

Selecting Inputs

1. Press **INPUT** on the remote or on the side of your HDTV to select the input source that matches the connection you made on the back of your HDTV. Repeated presses of **INPUT** cycles you through the options.
2. Turn on your component (cable box, VCR, satellite receiver, DVD player, etc.). You should see a picture on your HDTV. If you do not see a picture, press **INPUT** repeatedly until you do see a picture.

NOTE: If the selected input is RF, your HDTV needs to be on either channel 3 or 4 to match the channel on the VCR, cable box, external TV tuner or satellite receiver. Refer to the User's Manual of your equipment for details.

NOTE: Your HDTV will display the television station or program selected by the cable box, VCR, external tuner, or satellite receiver. Use the remote control that came with that component to change programs or channels. If the service being used is the one which setup includes a box with two outputs for two different (distant) rooms, then scanning channels will help you to find the signal. Be aware that the channel to be selected varies from provider to provider. You may have to call your provider to get the specific channel when using your HDTV. Some examples of these channels are 105, 106, 115, and 116.

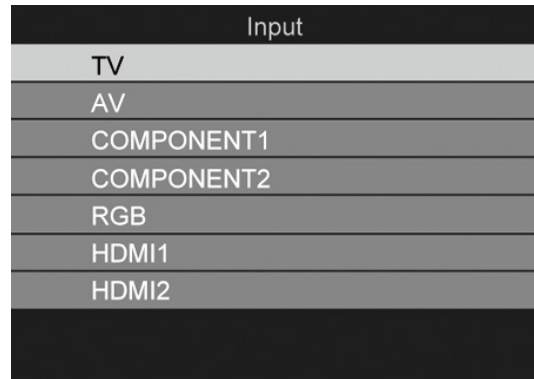

Fine-tuning the picture

1. Press **MENU** on the remote control. The *Picture* menu opens.
 2. Press **▲** or **▼** to select *Color Temperature*, then press **▶**. The *Color Temperature* menu opens.
 3. Press **◀** or **▶** to select *Normal*, then press **LAST** twice to return to the *Picture* menu.
 4. Press **▲** or **▼** to select *Picture Mode*.
 5. Press **▶** to select *Standard*.
- Press **LAST** repeatedly to exit the menu.

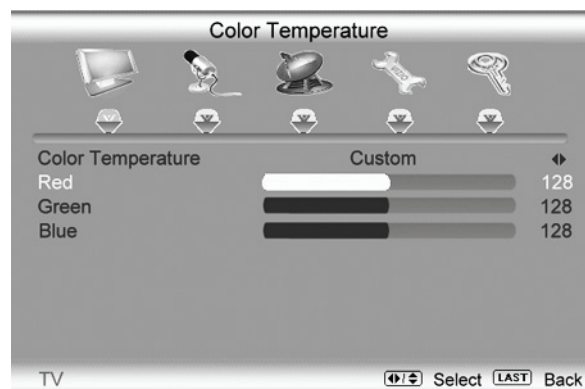
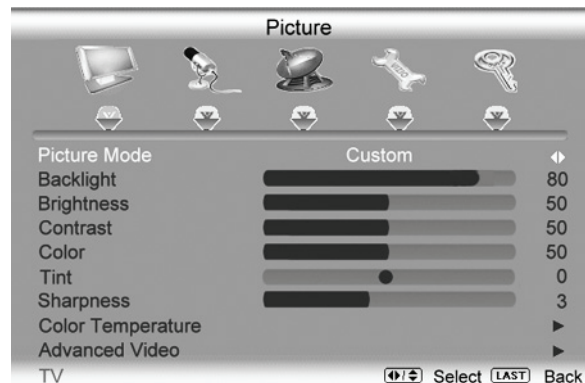

Using the Program Guide

1. Press **GUIDE** on the remote to display program information for the channel you are watching.
2. Press **GUIDE** to exit or wait for it to disappear automatically.

Displaying the Information Banner

When you change channels or inputs, an information banner displays the status of your HDTV.

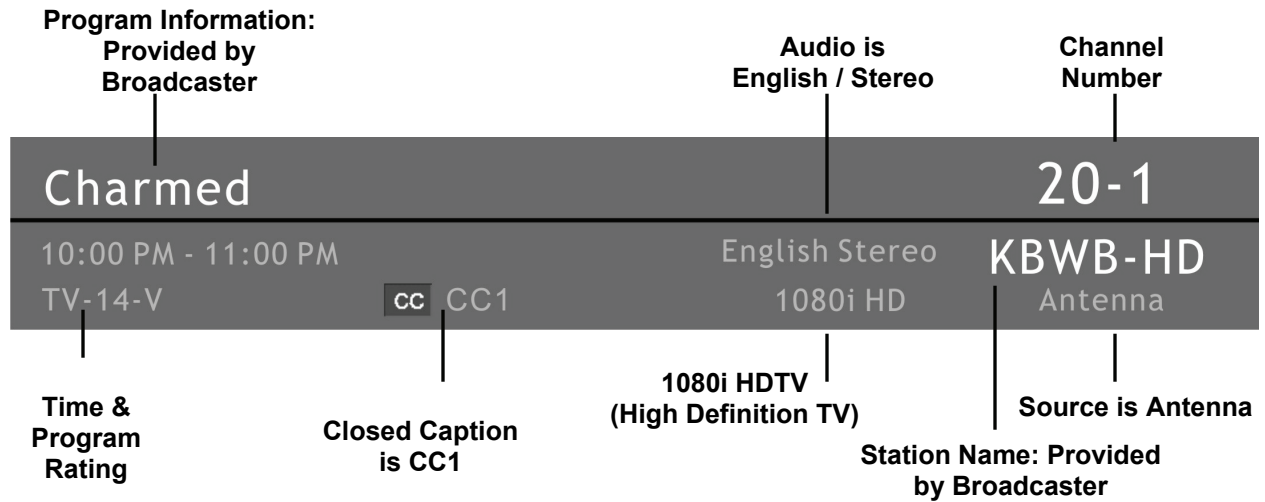

Using the On-Screen Display (OSD)

The remote control or the control buttons on the side of your HDTV control the function settings. The On-Screen Display (OSD) lets you adjust the contrast, brightness, and other settings. Changes are saved even when you turn off your HDTV. The OSD consists of these menu options:



Picture

Audio

TV

Setup

Parental Control

NOTE: The main menu options may vary depending on the selected input source.

1. Press **MENU** on the remote control or the side of your HDTV. The menu opens.
2. Press **◀** or **▶** on the remote control or **VOL +** or **VOL -** on the side of your HDTV to select an option.
3. Press **▲** or **▼** on the remote control or **CH +** or **CH -** on the side of your HDTV to select a sub-menu option.
4. Press **▶** on the remote control or **VOL -** on the side of your HDTV to adjust the item.
5. Press **LAST** when finished making adjustments.
6. Press **LAST** to return to the previous screen or repeatedly to exit the OSD.

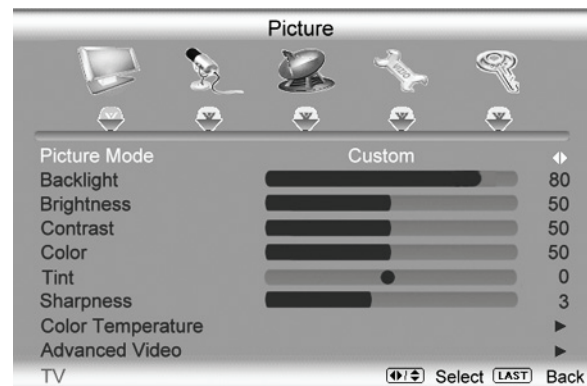

NOTE: "Not Available" will appear at the bottom of the OSD if menu items that are not available for adjustment.

Advanced Settings

Adjusting the Picture Settings

When viewing DTV / TV or an HDMI, Component, or AV source, the following picture adjustment OSD screens are available when you press **MENU** on the remote control. The source you are viewing is displayed in orange text in the bottom left-hand corner of the OSD.

Press **◀** / **▶** / **▲** / **▼** to select and adjust options, then press **LAST** when finished making adjustments. Press **LAST** to return to the previous screen or repeatedly to exit the OSD.



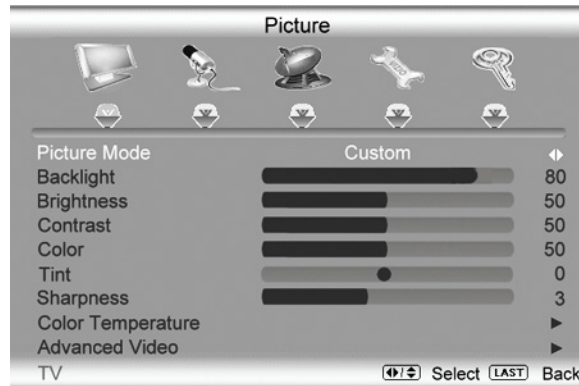

The following options are available in the *Picture* menu:

1. **Picture Mode** - Select *Custom*, *Standard*, *Movie*, *Game (Sports)*.
2. **Backlight** - Backlight adjusts the overall brilliance of the picture. It does not affect the Brightness (black level) or Contrast (white level) of the picture. If DCR is activated, backlight adjustment is not available.
3. **Brightness** - Brightness adjusts the black levels in the picture. If the brightness is too low you will not be able to see the detail in darker parts of the picture and if the brightness is too high the picture will look washed out.
4. **Contrast** - Contrast adjusts the white levels in the picture. If the contrast is too low the picture will look washed out and if the contrast is too high you will not be able to see any detail in the bright parts of a picture.
5. **Color** - The Color setting adjusts the amount of color in the picture.
6. **Tint** - The Tint adjusts the hue of the picture. The easiest way to set tint is to look at flesh tones and adjust for a realistic appearance. In most cases, the default middle position is correct.
7. **Sharpness** - The Sharpness setting adjusts the sharpness of the picture.
8. **Color Temperature** - Adjust your HDTV color temperature. Adjust *Red*, *Green*, and *Blue*.
9. **Advanced Video** -
 - **DNR** - DNR (Dynamic Noise Reduction) diminishes picture artifacts caused by the digitizing of moving images.
 - **Black Level Extender** - Black Level Extender extends grey levels to black to improve contrast.
 - **White Peak Limiter** - White Peak Limiter limits excessive white in bright areas of the picture.
 - **CTI** - Select CTI (Chrominance Transient Improvement) to reduce time transitioning from one color to another. The effect will be seen as sharpening the border between colors.
 - **Flesh Tone** - Adjust flesh tones of the picture. This may result in a more pleasing production of sky and flesh colors.
 - **Adaptive Luma** – Activation of this feature will raise the Average Picture Level (APL) to help lighten dark areas of the picture.
 - **DCR** (Dynamic Contrast Ratio) - DCR (Dynamic Contrast Ratio) automatically adjusts the contrast between brighter and darker scenes. When activated, adjustment of the Backlight is not available.



Adjusting the Audio Settings

When viewing a DTV / TV or an HDMI, Component, AV, or PC source, the following audio adjustment OSD screens are available when you press **MENU** on the remote control. The source you are viewing is displayed in orange text in the bottom left-hand corner of the OSD.

Press ◀ / ▶ / ▲ / ▼ to select and adjust options, then press **LAST** when finished making adjustments. Press **LAST** to return to the previous screen or repeatedly to exit the OSD.

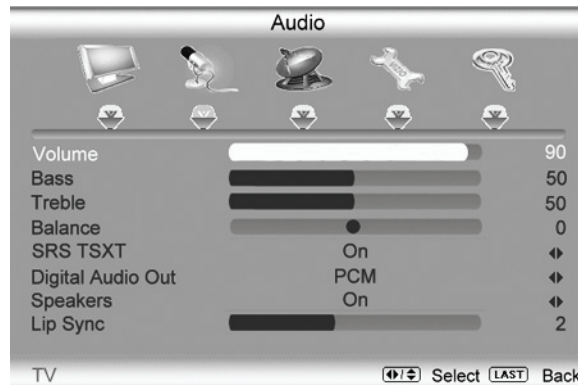

The following options are available in the *Audio Settings* menu:

1. **Volume** – Increase or decrease the HDTV speaker volume.
2. **Bass** – Adjust low frequency sounds. You can also adjust for bass boost or attenuation.
3. **Treble** – Adjust high frequency sounds. You can also adjust for treble boost or attenuation.
4. **Balance** – Adjust the sound to the left or right.
5. **SRS TSXT** – Turn the simulated surround feature *On* or *Off*.
6. **Digital Audio Out** – Send digital audio from your HDTV to an external audio system.
 - **Off** – Select to play audio through your HDTV speakers.
 - **PCM** - Select to output audio in 2-channel stereo.
 - **Dolby Digital** – Select to produces 5.1 channel Dolby Digital ® surround sound audio.
7. **Speakers** – Turn-off the internal TV speakers when listening to the audio through your home theater system.
8. **Lip Sync** – Adjust the audio of the program being viewed so that it matches the movement of the lips of someone talking on the screen.



Adjusting the TV settings

If you did not set up your HDTV for DTV / TV channels using the Initial Setup screens or if your setup has changed, you can do so from the *TV* menu.

Press ◀ / ▶ / ▲ / ▼ to select and adjust options, then press **LAST** when finished making adjustments. Press **LAST** to return to the previous screen or repeatedly to exit the OSD.

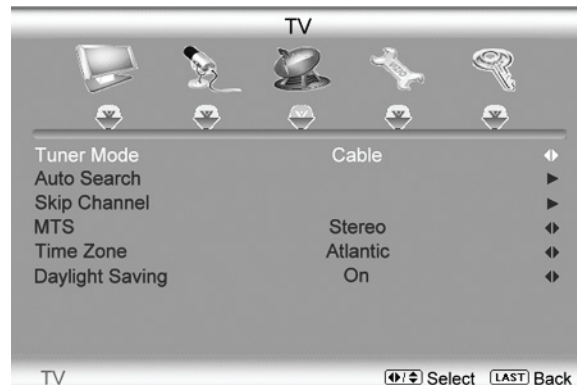

The following options are available in the *TV* menu:

1. **Tuner Mode** - Select *Cable* or *Antenna* (Air) depending upon the equipment you have connected to the DTV / TV Input.
2. **Auto Search** - Your HDTV can scan for channels in your area and store the channel information in the channel list. If a channel does not have a signal, your HDTV skips that channel. When you press CH ▲ or CH ▼, your HDTV changes to the next channel in the channel list.
3. **Skip Channel** - After your HDTV has stored all of the available DTV channels in memory, you can delete channels from the channel list that you do not want to see. You can still tune to deleted channels using the channel buttons on the remote control.
4. **MTS** - Multi-channel television sound (MTS) allows you to select *Stereo*, *SAP*, or *Mono*.
5. **Time Zone** - Setting the correct Time Zone for your area ensures that the correct program times are shown in the Electronic Program Guide.
6. **Daylight Saving** - Setting the daylight saving time for your area will ensure that the correct program times are shown in the Electronic Program Guide.



Adjusting the Setup settings

When viewing a DTV / TV or an HDMI, Component, AV, or PC source, the following setup adjustment OSD screens are available when you press **MENU** on the remote control.

NOTE: When a computer is the source, the **CC** option is not available.

Press ◀ / ▶ / ▲ / ▼ to select and adjust options, then press **LAST** when finished making adjustments. Press **LAST** to return to the previous screen or repeatedly to exit the OSD.

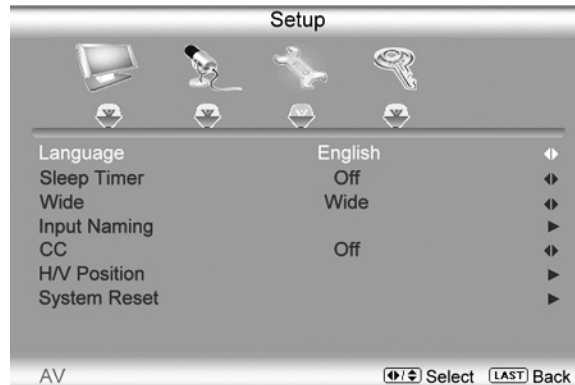

The following options are available in the *Setup* menu:

1. **Language** - Select the language displayed in the OSD menus.
2. **Sleep Timer** - Your HDTV can be set to turn off automatically after 30, 60, 90, or 120 minutes.
3. **Wide** - The *Wide* option lets you determine how the image appears on the screen. Select *Normal*, *Wide*, *Stretch*, or *Panoramic*.
4. **CC** - Adjust Closed Caption settings. Select *Off*, *CC1*, *CC2*, *CC3*, or *CC4*.
5. **H/V Position** – Adjust the horizontal and vertical aspects of the screen:
 - **H. Position** –Adjust the position of the screen left or right.
 - **V. Position** – Adjust the position of the screen up or down.
 - **H-SIZE** – Adjust the overall width of the screen.
 - **V-SIZE** – Adjust the overall height of the screen.
6. **System Reset** –
 - **Setup Wizard** – Use this function to return to the Initial Setup when the TV was used for the first time. See page 23 for more information.
 - Note:** Previously scanned channels will be removed.
 - **Reset All Settings** – Settings are reset to factory defaults. Press either the **MENU** button to go back or **LAST** to exit.

Note: This does NOT reset the Parental Control Password.



Adjusting the Parental Control settings

When viewing a DTV / TV or a component, or AV source, the following parental control OSD screens are available within the *Parental Control* OSD menu. Parental Control options are not available when viewing an HDMI source.

You can restrict certain channel and program viewing by turning on parental controls. Selected programs, movies and channels can then be made available only after an authorized password has been entered.

The default password is 0000.

Press ◀ / ▶ / ▲ / ▼ to select and adjust options, then press **LAST** when finished making adjustments. Press **LAST** to return to the previous screen or repeatedly to exit the OSD.

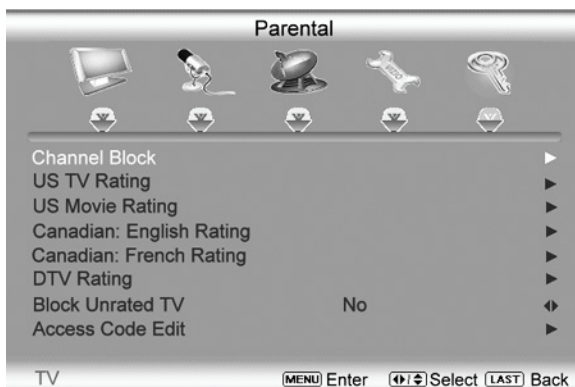

The following options are available in the *Parental* menu:

1. **Channel Block** - block individual channels.
2. **TV Rating** – Block TV shows based on their rating. Select the desired rating and press **MENU** to block (lock) or unblock (unlock).

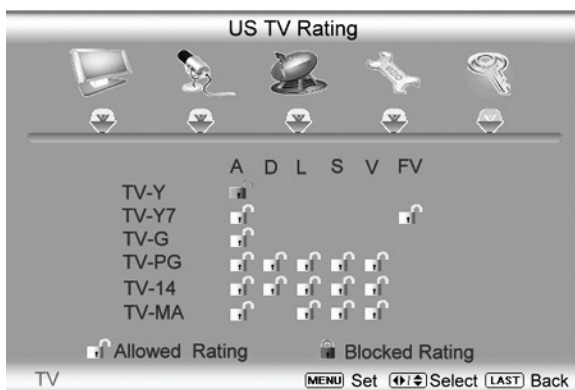

TV Rating Definitions:	TV Rating Content Definitions
Y – All children	A – All subratings
Y7 – Older children	D – Sexual dialog
G – General audience	L – Adult language
PG – Guidance suggested	S – Sexual situations
14 – Strongly cautioned	V - Violence
MA – Mature audience	FV – Fantasy violence



3. **Movie Rating** - Block TV shows based on their rating. Select the desired rating and press **MENU** to block (locked) or unblock (unlocked).

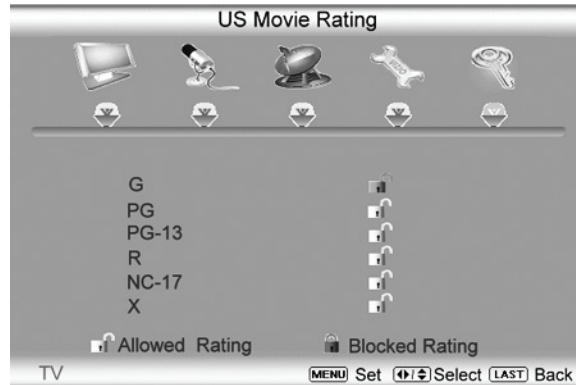

Movie Rating Definitions:	
G	– General audience
PG	– Parental guidance suggested
PG-13	– Recommended for children 13 years of age or older
R	– Mature audience
NC-17	– No one under 17 years of age
X	– No one under 17 years of age

4. **Check for New DTV Rating** - This option is designed to update the TV or Movie ratings table for programs being viewed in your local or regional area. It lets the parental guidance control feature in your HDTV to have the most current parental control database for a digital signal. If there is a red x in front of DTV Rating, no update is available or the option is not activated in your area.
5. **Blocked Unrated TV** - The *Blocked Unrated TV* option lets you block programming that does not have a rating.
6. **Access Code Edit** - The *Access Code Edit* option lets you change the password used to access the *Parental* menu. The default password from the factory is **0000**. Enter the new 4-digit password using the number buttons on the remote. Enter the password a second time to confirm you entered it correctly.

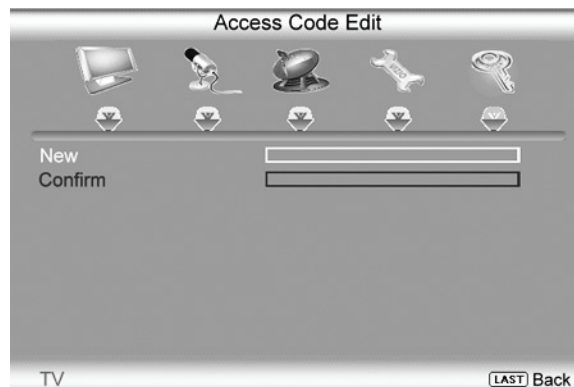

NOTE: Make sure you write down and store the new password in a secure place.



Understanding Viewing Modes

Your HDTV features the following viewing modes. You can switch viewing modes by pressing **WIDE** on the remote control.

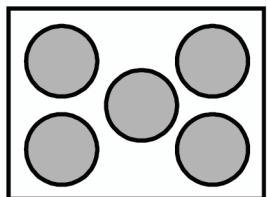

Normal Mode

The original 4:3 aspect ratio (1.33:1 source) is preserved, so black bars are added to the left and right of the display image. Standard TV broadcasts are displayed with a 4:3 Aspect Ratio. Movies in 4:3 Aspect Ratio may be referred to as pan-and-scan or full frame. These movies were originally filmed in 16:9 (widescreen), and then modified to fit a traditional TV screen (4:3).

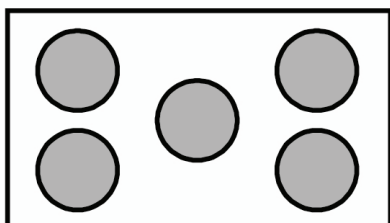

Wide Mode

When watching a standard broadcast or full-frame movie in this mode, the display image is stretched proportionately to fill the TV screen. When watching a widescreen (1.78:1 source) program or movie, the display image fills the TV screen. If you are watching a widescreen (1.85:1 or 2.35:1 source) program or movie, there will still be black bars at the top and bottom.

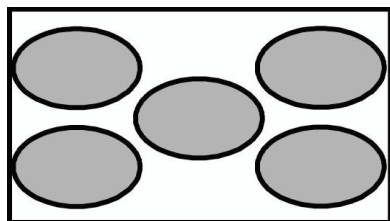

Stretch Mode

When watching a widescreen program (1.78:1 source) with black bars on the sides, the display image will stretch to fill the TV screen. People will appear wider than they really are. If you are watching a widescreen (1.85:1 or 2.35:1 source) program or movie, there will still be black bars at the top and bottom. This mode is available only when watching a widescreen program.

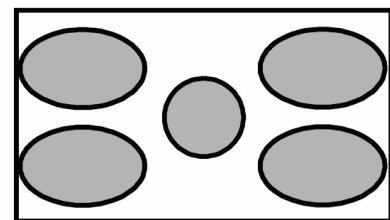

Panoramic Mode

When watching a standard broadcast or full-frame movie in this mode, the 4:3 Aspect Ratio (1.33:1 source) display image is stretched horizontally on the left and right sides to fill the TV screen. The center of the image is not stretched.



Maintaining and Troubleshooting

Maintenance

Important

1. Make sure that the power cord is removed from the socket before cleaning your HDTV.
2. Do not use volatile solvents (such as toluene, rosin, and alcohol) to clean your HDTV. Such chemicals may damage the housing, screen glass, and remote control, and cause paint to peel.

Cleaning the Housing and Remote Control

1. Use a soft cloth for cleaning.
2. If the housing or remote control is especially dirty, use a soft cloth moistened with diluted neutral cleaner to clean the display. Squeeze water out of the cloth before cleaning to prevent water from penetrating into the housing. Wipe the display with a dry cloth after cleaning.

Cleaning the Screen

1. Use a soft cotton cloth to gently clean the screen.
2. The screen glass is very fragile. Do not scrape it with any sharp object. Do not press or tap the screen or it may crack. When the screen is seriously contaminated, use a soft cloth moistened with a diluted neutral cleaner to clean the display. Squeeze water out of the cloth before cleaning to prevent water from penetrating into the housing. Wipe the display with a dry cloth after cleaning.

Reattaching the base

1. Lay the TV face down on a flat, level surface free from any debris.
2. Position the neck base by lining up the eight screw holes with those on the back of the TV.
3. Insert the eight screws and tighten.
4. Lift the TV to an upright position.



Troubleshooting

If your HDTV fails or the performance changes dramatically, follow the steps in the troubleshooting table below. Remember to check peripherals as well, to pinpoint the source of the failure. If your HDTV still fails to perform as expected, contact the VIZIO for assistance by calling 1-877-MYVIZIO (877-698-4946) or e-mail us at techsupport@VIZIO.com.

Problem	Solution
"No Signal" error message	<ul style="list-style-type: none"> Press INPUT to select a different source.
No power	<ul style="list-style-type: none"> Make sure the power is ON. The VIZIO logo will be white. Make sure the power cord is securely connected to the back of your HDTV and the power outlet. Connect another electrical device into the power outlet to verify that the outlet is supplying the proper voltage.
No sound	<ul style="list-style-type: none"> Check your audio connections on the back of your HDTV and on the back of the component. Make sure the volume is not turned down. Make sure that the sound is not muted. Make sure that headphones are not connected. Check your audio settings in the OSD. See "Adjusting the Audio Settings." Your HDTV audio may be set to SAP, minimum, or speakers off.
The screen is black	<ul style="list-style-type: none"> Check the connections on the back of your HDTV and on the back of the component. Make sure the power cord is securely connected to the back of your HDTV and a grounded power outlet. Make sure the power is ON. The VIZIO logo will be white. Make sure that the selected input source (i.e. DVD player) is working properly. If your HDTV is connected to your computer in RGB or HDMI mode, press any key on your keyboard to "wake" your computer.
Power is ON but there is no screen image.	<ul style="list-style-type: none"> Check the connections on the back of your HDTV and on the back of the component. Adjust brightness and contrast. Press INPUT to select a different source.
Colors are wrong or abnormal	<ul style="list-style-type: none"> If any colors (red, green, or blue) are missing, check the video cable to make sure it is securely connected.
Control buttons do not work	<ul style="list-style-type: none"> Press only one button at a time.
Remote Control does not work	<ul style="list-style-type: none"> Make sure batteries are inserted correctly. Replace expired batteries. Press the correct source on the remote control (i.e. TV to control the TV source).
Image quality issues	<ul style="list-style-type: none"> Standard, analog TV will always be noticeably inferior to HD because your digital flat panel TV has video that is many times better than older TVs. You will see interference and deficiencies you did not know you had. For best image quality, view HD wide screen programs where possible. If HD content is not available view "Standard Definition" from a digital source.
Picture is distorted	<ul style="list-style-type: none"> You may be getting interference from electrical appliances, cars, motorcycles, or fluorescent lights. If you have not mounted it on the wall, try moving your HDTV to another location to see if this is the cause of the problem. You may be getting interference from a device on the same electrical circuit. Try plugging your HDTV into another power outlet.
There is an unusual sound	<ul style="list-style-type: none"> You may be getting interference from electrical appliances, cars, motorcycles, or fluorescent lights. If you have not mounted it on the wall, try moving your HDTV to another location to see if this is the cause of the



Problem	Solution
	problem.
The picture has abnormal patterns	<ul style="list-style-type: none"> • Check the connections on the back of your HDTV and on the back of the component. • Make sure that the video input source is within the range of your HDTV. Compare the video input source's specifications with your HDTV specifications.
The display image does not cover the entire screen	<ul style="list-style-type: none"> • If you are in RGB mode (PC), make sure that H-Size and V.Position in the OSD are set correctly. See "Adjusting the Setup Settings" • Press WIDE on the remote control to scroll through the screen modes.
There is a picture but no sound	<ul style="list-style-type: none"> • Make sure that the volume is not turned down. • Make sure that the sound is not muted. • Check the connections on the back of your HDTV and on the back of the component.
Your HDTV has pixels that are always dark or colored	<ul style="list-style-type: none"> • Your HDTV is manufactured using an extremely high level of precision technology. However, some pixels of your TV may not display. Pixel defects within industry specifications are inherent to this type of product and do not constitute a defective product.
There is "noise" or "trash" on the screen	<ul style="list-style-type: none"> • When your HDTVs' digital capabilities exceed a digital broadcast signal, the signal is up-converted (increased) to match your HDTVs display capabilities. Up-converting can cause noise or trash.
The volume changes when you switch inputs	<ul style="list-style-type: none"> • Your HDTV remembers the volume level from the last time you adjusted it. If the sound level is higher or lower from another input, then the volume will change.
The screen size changes when you switch inputs	<ul style="list-style-type: none"> • The HDTV remembers the viewing mode from the last time you used a particular input (AV, Component, HDMI, and TV).
Backlight setting doesn't respond	<ul style="list-style-type: none"> • Disable DCR (Dynamic Contrast Ratio). Backlight settings will not work if DCR is enabled.

Telephone & Technical Support

Products are often returned due to a technical problem rather than a defective product which may result in unnecessary shipping charges billed to you. Our trained support personnel can often resolve the problem over the phone. For more information on warranty service or repair, after the warranty period, contact our Support Department at the number below.

Customer support and quality service are integral parts of VIZIO's commitment to service excellence. For technical assistance, contact our VIZIO Technical Support Department via e-mail or phone.

Email: **techsupport@vizio.com**
 (877) 698-4946 Fax: (949) 585-9563
 Hours of operation: Monday - Friday: 6 am to 9 pm
 Saturday – Sunday: 8 am to 4 pm
VIZIO
 Address:
 39 Tesla
 Irvine, CA 92618 USA
 Telephone: (949) 428-2525 Fax: (949) 585-9514
 Web: **www.vizio.com**

Have your VIZIO model number, serial number, and date of purchase available before you call.

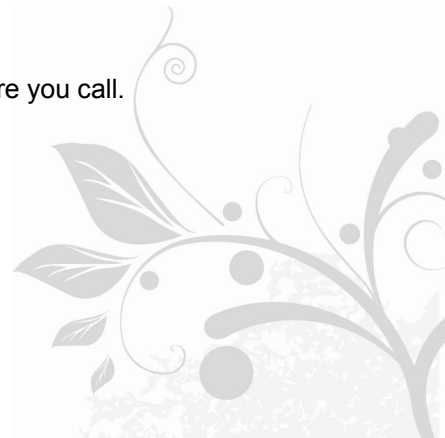

Regulations and Specifications

Compliance

Caution: Always use a power cord that is properly grounded. Use the AC cords listed below for each area.

Country	Power Cord
USA	UL
Canada	CSA
Germany	VDE
UK	BASE/BS
Japan	Electric Appliance Control Act

FCC Class B Radio Interference Statement

NOTE: This equipment has been tested and found to comply with the limits for a Class B digital device, pursuant to Part 15 of the FCC Rules. These limits are designed to provide reasonable protection against harmful interference in a residential installation. This equipment generates, uses and can radiate radio frequency energy, and if not installed and used in accordance with the instructions, may cause harmful interference to radio communications. However, there is no guarantee that interference will not occur in a particular installation. If this equipment does cause harmful interference to radio or television reception, which can be determined by turning the equipment off and on, the user is encouraged to try to correct the interference by one or more of the following measures:

1. Reorient or relocate the receiving antenna.
2. Increase the separation between the equipment and receiver.
3. Connect the equipment into an outlet on a circuit different from that to which the receiver is connected.
4. Consult the dealer or an experienced radio/TV technician for help.

Notice:

1. The changes or modifications not expressly approved by the party responsible for compliance could void the user's authority to operate the equipment.
2. Shielded interface cables and AC power cord, if any, must be used in order to comply with the emission limits.
3. The manufacturer is not responsible for any radio or TV interference caused by unauthorized modification to this equipment. It is the responsibilities of the user to correct such interference.



Specifications

Specifications	
Panel	31.5" Diagonal, 16:9 Aspect Ratio
Resolution	1366 x 768 pixels
Pixel (Dot) Pitch	0.5107mm (H) x 0.5107mm (V)
Display Compatibility	HDTV (720P)
Colors	16.77 Million (8-bit)
Brightness	450 cd/m ² (typical)
Contrast	2500:1 (typical), 12,500:1 (w/ DCR)
Response Time	6.5ms (typical)
Viewing Angle	Up to 178° (horizontal and vertical)
Inputs	1x Co-axial RF (ATSC/QAM/NTSC), 2x HDMI™ (v1.3) with HDCP (plus 1x Stereo Audio RCA for DVI source), 2x Component YPbPr plus Stereo Audio, 1x RGB PC plus Stereo Audio, 1x S-Video (AV) plus Stereo Audio, 1x Composite Video (AV)
Outputs	1x Digital Optical Audio 1x Stereo Audio
Features	HDMI v1.3, 720P HDTV, Dynamic Contrast Ratio technology, Noise reduction, MTS stereo decoder, Dolby Digital for ATSC/QAM, Signal Compatibility: 480i (SDTV), 480P (EDTV), 720P (HDTV), 1080i (HDTV), Channel skip, Video/input naming capability, Closed caption, Parental control/V-Chip 2.0, Virtual surround sound, ATSC/Clear QAM tuner, NTSC video decoding via RF or Composite video, 3:2 or 2:2 reverse pull-down, Motion adaptive de-interlace, Progressive video scan via Component video/VGA/HDMI, HDTV via HDMI or Component video, Color temperature adjustments of 6500K/9300K/11000K, Independent Red/Green/Blue adjustments for color temperature fine tuning, TV Signal Compatibility 480i (SDTV), 480P (EDTV), 720P (HDTV), 1080i (HDTV) and 1080P (FHDTV), Computer support at 640x480/800x600/1024x768/1366x768 via VGA/HDMI
Speakers	Built-in, 10W x 2
Panel Life	50,000 hours to half the original brightness
Power	
Input	IEC Connector for direct power line connection
Voltage Range	120Vac at 50/60Hz
Power Consumption	84W (average), 0.4W standby.
Environmental Conditions	
Operating	Temperature: 5°C~35°C, Relative Humidity: 20~80%, Altitude: 0~14,000 ft
Non-Operating	Temperature: -20°C~50°C, Relative Humidity: 10~90%, Altitude: 0~40,000 ft
Dimensions	31.38" W x 23.53" H x 8.95" D (797mm x 598mm x 228mm) with stand; 31.38" W x 22.13" H x 3.94" D (797mm x 562mm x 100mm) without stand
Net Weight	30.97 lbs (14.05kg) with stand; 29.76 lbs (13.5kg) without stand
Gross Weight	40.12 lbs (18.2kg)
Certifications	CSA/CSA-US, FCC Class B



Glossary - Standard Definitions

Analog TV: Today's TV system using radio frequency waves to transmit and display pictures and sound.

Aspect Ratio (4x3): Traditional TV "aspect ratio", that is, the screen's width as compared to its height. For example, a "32 inch TV screen" would be 25 inches wide and 19 inches tall.

Aspect Ratio (16x9): "Wide screen TV" aspect ratio which is more like a movie screen than a traditional TV. For example, a "32 inch TV screen" would be 28 inches wide and 16 inches tall.

Digital TV (DTV): Television delivered and displayed using radio frequency waves that contain information that is digitally encoded for improved quality and efficiency.

Enhanced Definition TV (EDTV): A better digital television transmission than SDTV with at least 480P, in a 16x9 or 4x3 display and Dolby digital surround sound. 480P is the quality used by most DVD players. EDTV provides 300-400,000 pixels.

HDTV Monitor (sometimes called HDTV Ready): A set that can display HDTV programming if you have a separate HDTV tuner, HD Cable Set-Top Box or HD Satellite Set-Top-Box Receiver.

HDTV Tuner (also decoder, receiver, set-top box): A device capable of receiving and outputting HDTV signals for display. It may be stand-alone or integrated in the set.

High-Definition Television (HDTV): The best quality picture, wide screen (16x9) display with at least 720 progressively scanned lines (720P) or 1080 interlaced lines (1080i) and Dolby digital surround sound. HDTV provides 900,000-2.1 million pixels.

Integrated HDTV: An HDTV that has the digital tuner built into the set. It does not need a separate set-top box to receive over-the-air DTV signals.

Interlace Scan: A way to scan vertical lines onto a TV picture by scanning all the odd lines first, then filling the in the even lines (this happens instantaneously).

Plug-and-Play or Digital Cable Ready: A DTV or other device for digital cable consumers that plugs directly into the cable jack and does not require a separate set-top box. Plug-and-Play TV owners must obtain a Cable CARD from their cable company in order to view scrambled programming services.

Progressive Scan: A way to scan vertical lines onto a TV picture by scanning all the lines consecutively (progressively).

Standard Definition TV (SDTV): Basic digital television transmission that may be displayed with fewer than 480 progressively scanned lines (480P) in 16 x 9 or 4 x 3 format. 480 interlaced (480i) is the quality of today's analog TV system.

Source: Buying a Digital Television, CEA, HDTV Guide, 2005

Note: The Federal Communications Commission (FCC), the Consumer Electronics Association (CEA) and the Consumer Electronics Retailers Coalition (CERC) have made a new tip sheet available for digital television (DTV) retailers to reproduce and distribute to consumers on the sales floor. The file may be downloaded online at www.dtv.gov. While you're there, check out the other useful information in the FCC is making available to consumers interested in learning more about the analog to digital transition.



VIZIO LIMITED PRODUCT WARRANTY

VIZIO provides a "ONE-YEAR LIMITED WARRANTY" against manufacturing defects in materials and workmanship to the original purchaser of a new VIZIO display purchased from an authorized VIZIO U.S. reseller and used in the fifty (50) United States or Puerto Rico.

VIZIO's Responsibility

VIZIO displays purchased new from an authorized VIZIO U.S. reseller and that are used in the fifty (50) United States or Puerto Rico are warranted to be free from manufacturing defects in materials and workmanship for one (1) year from the date of the original retail purchase. If the display fails to conform to this limited warranty, VIZIO will, at its option and sole discretion, repair or replace the display.

Labor

During the one-year limited warranty period, VIZIO will provide, when needed, service labor to repair a manufacturing defect. Repairs required on displays which are thirty (30) inches and larger generally will be made "on-site" where the display is installed. The determination for performing the on-site repair is dependent upon the manufacturing defect and is at VIZIO's option and sole discretion. Repairs required on displays which are less than thirty (30) inches generally will be performed at a VIZIO service center.

Parts

Repairs may be made with new or recertified parts, or the entire unit may be replaced with a new or recertified unit, at VIZIO's option and sole discretion. Replacement parts or replacement units provided under this limited warranty are warranted for the remaining portion of the original warranty period, or for ninety (90) days from warranty service or replacement, whichever is later.

How to Obtain Warranty Service

To obtain warranty service, contact VIZIO Technical Support via email at TechSupport@VIZIO.com, via phone at 877-MYVIZIO (877-698-4946), or via postal mail at VIZIO Technical Support, 39 Tesla, Irvine, CA 92618. You must provide the model, serial number, and date of purchase. VIZIO Technical Support is available from 6:00AM to 9:00PM Pacific Time, Monday through Friday, and 10:00AM to 2:00PM Pacific Time, Saturday and Sunday. Please note that holiday hours may vary. For up to date information, please visit www.VIZIO.com.

VIZIO reserves the right to assess all warranty claims and to determine if defects or damages are covered by this limited warranty. In case of a claim that is not covered by this warranty, you will be contacted to determine whether VIZIO should repair the damage for a fee or whether the product should be returned to you as received by the service technician or service center.

Parts and service labor that are VIZIO's responsibility under this limited warranty will be provided without charge. All other service is at the customer's expense. VIZIO reserves the right to charge the customer for any service call for anything not covered by this limited warranty. Before you ask for warranty service, please review your User Manual. You may avoid a service call and a service charge.

Please refer to the reverse side of this page for additional information regarding how to obtain warranty service.

PLEASE DO NOT RETURN YOUR UNIT TO VIZIO WITHOUT PRIOR AUTHORIZATION.



Not Covered

This limited warranty does not cover the following: cosmetic defects; damage, malfunctions or failures resulting from shipping or transit, improper or faulty installation, abuse, operation contrary to furnished instructions, operation on incorrect power supplies, products not supplied by VIZIO, modification, alteration, improper servicing or tampering; damage from fire, water, lightning, power surges, abnormal environmental conditions or other acts of nature; normal wear and tear; unsatisfactory visual or audio performance not caused by a manufacturing defect; or displays with a missing or unreadable serial number. Operation of the display for commercial purposes or in applications or uses for which the display is not intended is not covered by this limited warranty. "Image Sticking", caused by static images on the screen for extended periods and or excessive brightness and contrast levels, is not covered by this limited warranty. Installation, removal, transportation and reinstallation of a display, and routine maintenance and cleaning, are not covered by this limited warranty.

THERE ARE NO EXPRESS WARRANTIES OTHER THAN THOSE LISTED OR DESCRIBED ABOVE. ANY IMPLIED WARRANTIES, INCLUDING ANY IMPLIED WARRANTY OF MERCHANTABILITY AND FITNESS FOR A PARTICULAR PURPOSE, SHALL BE LIMITED IN DURATION TO THE PERIOD OF TIME SET FORTH ABOVE. VIZIO'S TOTAL LIABILITY FOR ANY AND ALL LOSSES AND DAMAGES RESULTING FROM ANY CAUSE WHATSOEVER, INCLUDING VIZIO'S NEGLIGENCE, ALLEGED DAMAGE, OR DEFECTIVE GOODS, WHETHER SUCH DEFECTS ARE DISCOVERABLE OR LATENT, SHALL IN NO EVENT EXCEED THE PURCHASE PRICE OF THE DISPLAY. VIZIO SHALL NOT BE RESPONSIBLE FOR LOSS OF USE, COMMERCIAL LOSS, LOST REVENUE OR LOST PROFITS, OR OTHER INCIDENTAL OR CONSEQUENTIAL DAMAGES. SOME STATES DO NOT ALLOW LIMITATIONS ON HOW LONG AN IMPLIED WARRANTY LASTS OR THE EXCLUSION OR LIMITATION OF INCIDENTAL OR CONSEQUENTIAL DAMAGES, SO THE ABOVE LIMITATIONS OR EXCLUSIONS MAY NOT APPLY TO YOU.

This warranty gives you specific legal rights, and you may also have other rights, which vary from state to state. This is the only warranty applicable; no one is authorized to extend or modify it or to grant any other warranty on VIZIO's behalf.

Owner's Responsibility

To ensure warranty service, keep the dated bill or sales receipt as evidence of the purchase date and location. This limited warranty applies only to original purchaser and is non-transferable.

Note: Warranty service conditions are subject to change. For the latest Warranty Terms and Conditions and additional information regarding VIZIO's Limited Product Warranty, please see complete details online at www.VIZIO.com.

VIZIO RETURN POLICY

VIZIO's return policy allows for products purchased directly from VIZIO to be returned by the original purchaser during the initial thirty (30) day period following the date of purchase. A VIZIO return authorization number must first be obtained as provided below. The refund will be the purchase price actually paid by the purchaser less a ten percent (10%) restocking fee per each item returned. Shipping and handling are not refundable.

The return authorization number must first be obtained from VIZIO's Customer Service by emailing CustomerSupport@VIZIO.com or by calling 949-428-2525, 6:00AM to 9:00PM Pacific Time, Monday through Friday, and 10:00AM to 2:00PM Pacific Time, Saturday and Sunday. Please note that holiday hours may vary. For up to date information, please visit www.VIZIO.com.

Products must be returned to the address specified by VIZIO Customer Service and must be shipped in the original packaging, with freight prepaid to VIZIO, and must be received in new and unused condition. The return authorization number must be included in the packaging. VIZIO reserves the right to assess fees for any damaged or missing parts in addition to the ten percent (10%) restocking fee.



Return authorization numbers are valid for only fifteen (15) days from issuance. The customer is responsible for and must prepay all shipping charges and shall assume all risk of loss or damage to the product while in transit to VIZIO. If the product is returned to VIZIO (i) without a VIZIO return authorization number, and/or (ii) beyond the fifteen (15) day period, and/or (iii) without proper packaging, VIZIO retains the right to refuse delivery of such return or may return the unit to the customer at the customer's expense and with no refund issued. This return policy does not apply to defective products. Please read VIZIO's Limited Product Warranty for warranty terms and conditions.

Warranty Replacement Procedure

Warranty Replacement generally is performed on displays which are determined to be economically unrepairable.

If VIZIO Technical Support determines that a problem with a display unit may be within the terms and conditions of the VIZIO Limited Product Warranty and that a repair is not economically possible, based on certain manufacturing defects in materials and/or workmanship, and/or at VIZIO's option and sole discretion, the customer will be provided with a return authorization number and replacement instructions. Proof of purchase is required to confirm the product is within the one-year limited warranty period and meets the terms and conditions of the VIZIO Limited Product Warranty.

For displays forty-two inches (42") and larger, VIZIO will generally cover the transportation charges to perform an on-site swap of the original unit with the replacement unit. For displays under forty-two inches (42"), the customer is responsible for the transportation charges to VIZIO's service center. VIZIO will be responsible for the return transportation charges from the service center to the customer. Please read VIZIO's Limited Product Warranty for warranty terms and conditions.

Mail-In Warranty Repair Procedure

Mail-In Warranty Repair generally is performed on displays which are smaller than 30 inches.

If VIZIO Technical Support determines that a problem with a display unit may be within the terms and conditions of the VIZIO Limited Product Warranty and that a mail-in repair may be performed, the customer will be provided with a return authorization number and mail-in repair instructions. Proof of purchase is required to confirm the product is within the one-year limited warranty period and meets the terms and conditions of the VIZIO Limited Product Warranty.

The customer will be provided with instructions for packing and shipping the unit to the VIZIO service center. The original carton box and packing material, or an equivalent as designated by VIZIO, must be utilized. The cost of shipping to VIZIO's service center is at the customer's expense. After the product is repaired and tested, the VIZIO service center will ship the unit back to the customer at VIZIO's expense. VIZIO is not responsible for the de-installation or re-installation of the product. Please read VIZIO's Limited Product Warranty for warranty terms and conditions.

PLEASE DO NOT RETURN YOUR UNIT TO VIZIO WITHOUT PRIOR AUTHORIZATION.



Index

- AC IN jack, 8
- access code
 - changing, 33
- accessories, 5
- Adjustments
 - Selecting the Screen Size, 40
- advanced video settings
 - black level extender, 28
- antenna
 - setting as TV signal source, 30
- antenna grounding, 3
- antenna jack, 8
- aspect ratio
 - descriptions, 34
 - selecting, 31
- audio settings
 - adjusting, 29
 - lip sync, 29
 - speakers, 29
 - surround mode, 29
- AV In jack, 8
- backlight
 - adjusting, 28
- black level extender, 28
- blocking channels, 32
- brightness
 - adjusting, 28
- cable
 - setting as TV signal source, 30
- CC (Closed Caption)
 - selecting, 31
- channel block
 - selecting, 32
- channel buttons, 7
- channels
 - deleting, 30
 - searching for, 30
- cleaning
 - remote control, 35
 - screen, 35
- Coax (RF)
 - Connecting for DTV, 13
 - Connecting your Basic Set Top Box, 16
- color
 - adjusting, 28
- color temperature
 - adjusting, 28
- Component
 - Connecting your DVD Player, 18
 - Connecting your HDTV Set-Top Box, 15
- component jacks, 8
- Composite (AV)
 - Connecting your DVD Player, 19
- contrast
 - adjusting, 28
- CTI, 28
- daylight saving
 - selecting, 30, 31
- DNR, 28
- DTV
 - jack, 8
- DVI
 - Connecting your DVD Player, 17
 - Connecting your HDTV Set-Top Box, 14
- dynamic noise reduction, 28
- FCC Bulletin for New TV Owners, 3
- FCC statement, 38
- fine-tuning the picture, 25
- flesh tone, 28
- front bezel, 7
 - power indicator, 7
 - remote control sensor, 7
- Glossary, 40
- HDMI
 - Connecting your DVD Player, 17
 - Connecting your HDTV Set-Top Box, 14
- HDMI 1 jack, 8
- HDMI 2 jack, 8
- information banner, 26
- installation services, 5
- language
 - selecting OSD, 31
- lip sync
 - turning off and on, 29
- maintaining, 35
- MENU button, 7
- movie ratings
 - blocking, 33
- MTS
 - Stereo, SAP, Mono, 30
- Normal aspect ratio, 34
- On-Screen Display, 27
 - selecting language, 31
- OSD, 27
 - Brightness Adjustment, 39
 - Contrast Adjustment, 39
 - selecting language, 31
- Outputs
 - Using 5.1 Surround with a Home Theatre System, 20
- package contents, 5
- Panoramic aspect ratio, 34
- parental control
 - access code edit, 33



- block unrated TV, 33
- channel block, 32
- check for new DTV rating, 33
- movie rating, 33
- options, 32
- TV rating, 32
- password
 - changing, 33
- PC Resolutions, 22
- picture settings, 27
 - advanced video, 28
 - backlight, 28
 - brightness, 28
 - color, 28
 - color temperature, 28
 - contrast, 28
 - sharpness, 28
 - tint, 28
- power button, 7
- power connector, 8
- power cord, 38
- power indicator, 7
- program guide, 26
- rear jacks
 - AC IN, 8
 - antenna, 8
 - AV In, 8
 - component, 8
 - HDMI 1, 8
 - HDMI 2, 8
 - power connector, 8
 - RGB PC, 8
- remote control
 - buttons, 9
 - installing batteries, 10
 - range, 10
 - safety, 10
 - sensor, 7
- Remote Control
 - Using your Cable or Satellite Remote to Operate your VIZIO TV, 10
- resetting
 - all settings, 31
- return policy, 42
- RGB
 - Connecting your PC, 21
- RGB PC jacks, 8
- safety instructions, 2
- SAP
 - selecting, 30
- setting up, 11
 - first time usage, 23
 - selecting video connection, 12
- setup menu
 - closed caption, 31
 - language, 31
 - options, 31
 - reset all setting, 31
 - sleep timer, 31
 - wide, 31
- sharpness
 - adjusting, 28
- side panel controls, 7
 - channel buttons, 7
 - MENU button, 7
 - power button, 7
 - volume buttons, 7
- sleep timer
 - setting, 31
- speakers
 - turning off and on, 29
- support
 - technical, 37
 - telephone, 37
- surround mode
 - turning off and on, 29
- S-Video
 - Connecting your DVD Player, 18
 - Connecting your VCR, 19
 - Connecting your Video Camera, 20
- Technical Specifications, 39
- technical support, 37
- telephone support, 37
- time zone
 - selecting, 30
- tint
 - adjusting, 28
- troubleshooting, 35, 36
- tuner mode
 - selecting, 30
- TV
 - settings
 - adjusting, 30
- TV ratings
 - blocking, 32
- TV signal source
 - selecting, 30
- TV tuner settings
 - adjusting, 30
 - auto search, 30
 - daylight saving, 30
 - deleting channels, 30
 - MTS, 30
 - searching for channels, 30
 - skipping channels, 30
 - time zone, 30
 - tuner mode, 30
- unrated TV
 - blocking, 33
- update rating, 33
- video
 - adjusting, 28



video connection types, 12

video input

selecting, 25

video settings

adaptive luma, 28

adjusting, 28

CTI, 28

DNR, 28

flesh tone, 28

white peak limiter, 28

viewing modes

descriptions, 34

volume buttons, 7

wall mounting, 11

warranty services, 5

warranty, 41

white peak limiter, 28

Wide

16:9, 31

4:3, 31

