



VIZIO

Dear VIZIO Customer:

Congratulations on your new VIZIO VMM26 F20I LCD monitor purchase. To get the maximum benefit from your monitor, read these instructions before making any adjustments, and retain them for future reference. We hope you will experience many years of enjoyment from your new monitor.

For assistance, call **(877) 698-4946** or e-mail us at **techsupport@VIZIO.com**.

To purchase or inquire about accessories and installation services for your monitor, visit our website at **www.VIZIO.com** or call toll-free at **888-VIZIOCE (888-849-4623)**.

We recommend you register your monitor either by visiting our website (www.VIZIO.com) or by completing and mailing in your registration card. For peace of mind and to protect your investment beyond the standard warranty, VIZIO offers on-site extended warranty service plans. These plans give additional coverage during the standard warranty period. Visit our website or call us to purchase a plan.

Write down the serial number located on the back of your monitor.

Purchase Date _____

VIZIO is a registered trademark of VIZIO, Inc. DBA V, Inc.



HDMI logo and "High-Definition Multimedia Interface" are registered trademarks of HDMI Licensing LLC.

Manufactured under license from Dolby Laboratories. Dolby and the double-D symbol are trademarks of Dolby Laboratories.



Important safety instructions

Your monitor is designed and manufactured to operate within defined design limits, and misuse may result in electric shock or fire. To prevent your monitor from being damaged, read and follow these safety instructions for installing, using, and maintaining your monitor. Keep these instructions for future reference.

- To reduce the risk of electric shock or component damage, turn off the power before connecting other components to your monitor.
- Unplug the power cord before cleaning your monitor. A damp cloth is sufficient for cleaning your monitor. Do not use a liquid or a spray cleaner for cleaning your monitor. Do not use abrasive cleaners.
- Always use the accessories recommended by the manufacturer to ensure compatibility.
- When moving your monitor from an area of low temperature to an area of high temperature, condensation may form inside the housing. Wait until the condensation has evaporated before turning on your monitor to avoid causing fire, electric shock, or component damage.
- Use only with the cart, stand, tripod, bracket, or table specified by the manufacturer or sold with your monitor. When a cart is used, use caution when moving the cart/monitor combination to avoid injury from tip-over. Do not place your monitor on an unstable cart, stand, or table. If your monitor falls, it can injure a person and cause serious damage to your monitor. Use only a cart or stand recommended by the manufacturer or sold with your monitor. 
- A distance of at least 3 feet should be maintained between your monitor and any heat source, such as a radiator, heater, oven, or amplifier. Do not install your monitor close to smoke. Operating your monitor close to smoke or moisture may cause fire or electric shock.
- Slots and openings in the back and bottom of the cabinet are provided for ventilation. To ensure reliable operation of your monitor and to protect it from overheating, make sure that these openings are not blocked or covered. Do not place your monitor in a bookcase or cabinet unless proper ventilation is provided.
- Never push any object into the slots and openings on your monitor cabinet. Do not place any objects on the top of your monitor. Doing so could short-circuit parts, causing a fire or electric shock. Never spill liquids on your monitor.
- Your monitor should be operated only from the type of power source indicated on the label. If you are not sure of the type of power supplied to your home, consult your dealer or local power company.
- The power cord must be replaced when using different voltage than the voltage specified. For more information, contact your dealer.
- Your monitor is equipped with a three-pronged grounded plug (a plug with a third grounding pin). This plug will fit only into a grounded power outlet. This is a safety feature. If your outlet does not accommodate the three-pronged plug, have an electrician install the correct outlet, or use an adapter to ground your monitor safely. Do not defeat the safety purpose of the grounded plug.
- Power is always flowing into your monitor when it is connected to a power outlet. To completely disconnect power, unplug the power cord.
- The lightning flash with arrowhead symbol within an equilateral triangle is intended to alert the user to the presence of un-isolated, dangerous voltage within the inside of your monitor that may be of sufficient magnitude to constitute a risk of electric shock to persons. 



- The exclamation point within an equilateral triangle is intended to alert the user to the presence of important operating and servicing instructions in the literature accompanying your monitor.
- Do not overload power strips and extension cords. Overloading can result in fire or electric shock.
- The power outlet should be installed near your monitor and easily accessible.
- Only power of the marked voltage can be used for your monitor. Any other voltage than the specified voltage may cause fire or electric shock.
- Do not touch the power cord during a lightning storm. To avoid electric shock, avoid handling the power cord during electrical storms.
- Unplug your monitor during a lightning storm or when it will not be used for long period of time. This will protect your monitor from damage due to power surges.
- Do not attempt to repair or service your monitor yourself. Opening or removing the back cover may expose you to high voltages, electric shock, and other hazards. If repair is required, contact your dealer and refer all servicing to qualified service personnel.
- Keep your monitor away from moisture. Do not expose your monitor to rain or moisture. If water penetrates into your monitor, unplug the power cord and contact your dealer. Continuous use in this case may result in fire or electric shock.
- Do not use your monitor if any abnormality occurs. If any smoke or odor becomes apparent, unplug the power cord and contact your dealer immediately. Do not try to repair your monitor yourself.
- Avoid using dropped or damaged appliances. If your monitor is dropped and the housing is damaged, the internal components may function abnormally. Unplug the power cord immediately and contact your dealer for repair. Continued use of your monitor may cause fire or electric shock.
- Do not install your monitor in an area with heavy dust or high humidity. Operating your monitor in environments with heavy dust or high humidity may cause fire or electric shock.
- Follow instructions for moving your monitor. Ensure that the power cord and any other cables are unplugged before moving your monitor.
- When unplugging your monitor, hold the power plug, not the cord. Pulling on the power cord may damage the wires inside the cord and cause fire or electric shock. When your monitor will not be used for an extended period of time, unplug the power cord.
- To reduce risk of electric shock, do not touch the connector with wet hands.
- If any of the following occurs, contact the dealer:
 - The power cord fails or frays.
 - Liquid sprays or any object drops into your monitor.
 - Your monitor is exposed to rain or other moisture.
 - Your monitor is dropped or damaged in any way.
 - The performance of your monitor changes substantially.



Contents

Important safety instructions	2
Features	6
Opening the Package	6
Front	6
Side	7
Back	8
Setting Up Your Monitor	8
Attaching the Stand	8
Connecting to a Computer	11
HDMI Connection	11
DVI Connection	11
VGA Connection	11
Connecting USB Devices	11
Adjusting the Height, Tilt, and Swivel	11
Connecting the Power Cord	12
Wall-mounting your monitor	12
Using Your Monitor	12
Turning On Your Monitor	12
Adjusting Monitor Settings	13
OSD Options	13
Maintaining and Troubleshooting	15
Maintaining	15
Cleaning the case	15
Cleaning the screen	15
Troubleshooting	15
Specifications and Regulations	17
Specifications	17
Regulations	18



Index 19

VIZIO Limited Product Warranty 20

VIZIO Return Policy 21

On-Site Warranty Repair Procedure 22
Warranty Replacement Procedure 22
Mail-In Warranty Repair Procedure 23



Features

Opening the Package

Your monitor and its accompanying accessories are carefully packed in a cardboard carton that has been designed to protect it from transportation damage. After you have opened the carton, check that your monitor is in good condition and that all of the contents are included.

The glass surface can easily be scratched or broken, so handle your monitor gently and never place your monitor with the glass facing downwards on a surface without protective padding.

The package contains:

- Monitor
- Stand assembly
- VGA cable
- DVI cable
- Audio cable
- Power cord
- USB upstream cable

Front



#	Button	Description
1	∧	Touch to scroll up through menus and options.
2	∨	Touch to scroll down through menus and options.
3	OK	Touch to confirm selections or changes.



#	Button	Description
4	→	Touch to go to a previous menu or to exit the on-screen display (OSD).
5	⏻	Touch to turn your monitor on or off. When the VIZIO logo is: <ul style="list-style-type: none"> • White—Monitor is on and receiving a video signal. • Orange—Monitor is on and in standby mode. • Off—Monitor is turned off.

Side

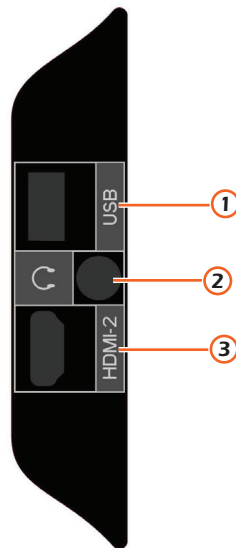

#	Port	Description
1	USB	Plug USB devices into these ports.
2	Headphone	Plug headphones into this port.
3	HDMI-2	Plug an HDMI device into this port.



Back

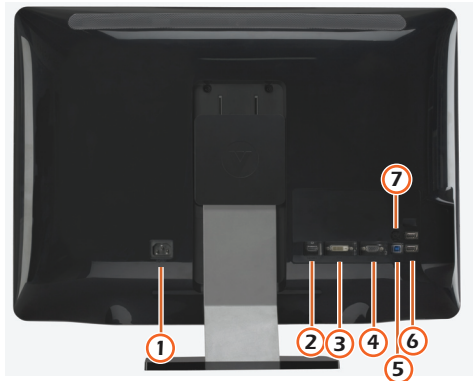

#	Port	Description
1	Power	Connect the power cord to this port.
2	HDMI-1	Connect a computer or an HDMI device to this port.
3	DVI	Connect a DVI device to this port.
4	VGA	Connect a computer with a VGA port to this port.
5	USB IN (upstream)	Connect the upstream USB cable to your monitor and to a USB port on the computer.
6	USB	Connect a USB device to this port.
7	AUDIO IN	Connect a computer's audio to this port.

Setting Up Your Monitor

Attaching the Stand

To attach the stand:

- 1 Slide the base onto the arm.

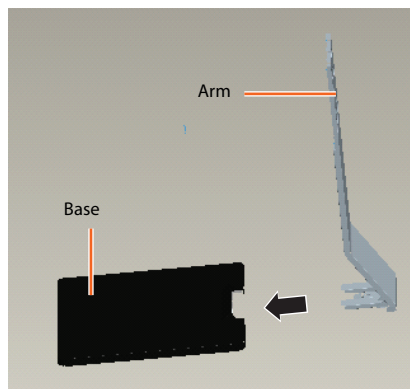

- 2 Insert the thumbscrew into the mounting hole on the bottom of the base, then tighten the thumbscrew.

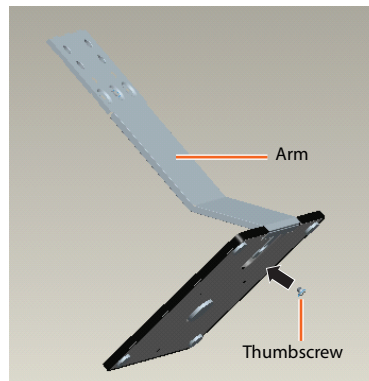

- 3 Lay your monitor screen face-down on a padded surface, such as a towel, then slide the arm into the mounting bracket on the back of the screen.

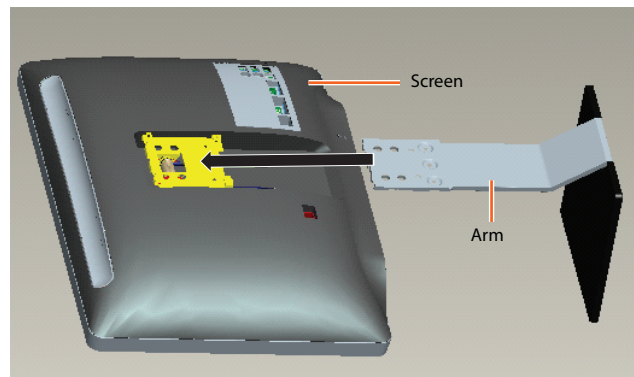

- 4 Insert the thumbscrew into the mounting hole on the back of the arm, then tighten the thumbscrew to secure your monitor to the arm.

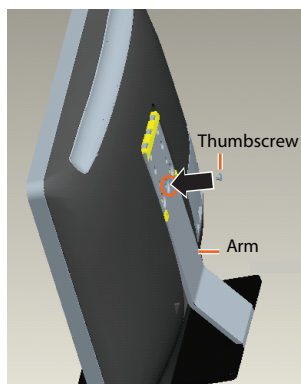

- 5 Snap the cover onto the top of the arm where the thumbscrew is.

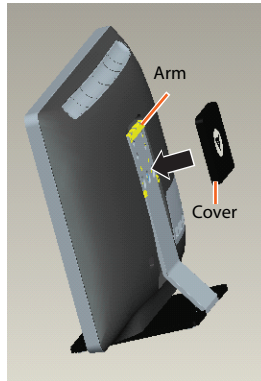

- 6 Set your monitor into the upright position.



Connecting to a Computer

Your monitor has several types of ports for connecting a computer. For more information, see “Back” on page 8 or “Side” on page 7.

HDMI Connection

Warning:

Make sure that your monitor and the device you are connecting are turned off and the power cords are unplugged.

To connect a computer using HDMI:

- 1 Connect one end of an HDMI cable to the **HDMI1** port on the back of your monitor.
- 2 Connect the other end of the cable to the **HDMI OUT** port on the computer.

DVI Connection

Warning:

Make sure that your monitor and the device you are connecting are turned off and the power cords are unplugged.

To connect a computer using DVI:

- 1 Connect one end of a DVI cable to the **DVI** port on the back of your monitor.
- 2 Connect the other end of the cable to the **DVI OUT** port on the computer.

VGA Connection

Warning:

Make sure that your monitor and the device you are connecting are turned off and the power cords are unplugged.

To connect a computer using VGA:

- 1 Connect one end of a VGA cable to the **VGA** port on the back of your monitor.
- 2 Connect the other end of the cable to the **VGA** port on the computer.

Connecting USB Devices

You can connect USB devices, such as a camcorder, to the USB ports on the side or back of your monitor.

Note:

You must connect the USB upstream cable to the USB IN (upstream) port on your monitor and to a USB port on a computer. If you do not make this connection, the USB ports on your monitor will not work.

To connect a USB device:

- 1 Connect the USB upstream cable to the **USB IN** (upstream) port on your monitor.
- 2 Connect the other end of the cable to a **USB** port on the computer.
- 3 Connect a USB cable to a **USB** port on the side or back of your monitor.
- 4 Connect the other end of the cable to the USB device.

Adjusting the Height, Tilt, and Swivel

You can adjust the height and tilt of your monitor’s screen.

To adjust the height:

- Grasp each side of the screen, then slide the screen up or down.



To adjust the tilt:

- Grasp the top and bottom of the screen, then push or pull the top of the screen backward or forward.

To adjust the swivel:

- Grasp each side of the screen, then swivel the screen left or right.

Connecting the Power Cord

To connect the power cord:

- 1 Plug the power cord into the power connector on the back of your monitor.
- 2 Plug the other end of the cord into a power outlet.



Wall-mounting your monitor

Wall-mounting kits are sold separately. Follow the manufacturer's instructions. Wall-mount brackets must be VESA 100 compliant.

Using Your Monitor

Turning On Your Monitor

To turn on your monitor:

- 1 Make sure that you have connected the power cord to your monitor and a power outlet.
- 2 Press the power  button on the front of your monitor. The VIZIO logo lights white.
- 3 Turn on the computer. If your monitor detects no input signal, the VIZIO logo lights orange.
- 4 To turn off your monitor, press and hold the power  button for three seconds. A counter appears on the screen. When the counter reaches 1, your monitor turns off.



Adjusting Monitor Settings

Your monitor has an on-screen display (OSD) that lets you adjust monitor settings. Your monitor retains the settings even if you turn it off.

To adjust monitor settings:

- 1 Touch the area above the power button LED indicator. This area lights up with the **Auto Adjust** option selected.

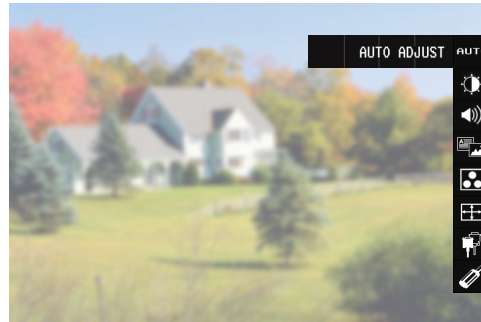





- 2 Press the \wedge or \vee arrow to select the option you want to adjust, then press **OK**.
- 3 If a submenu opens, press the \vee arrow to select the option you want to adjust, then press **OK**.
- 4 Press the \wedge or \vee arrow to adjust the option, then press **OK**. If you have selected the wrong option, press the \rightarrow arrow to return to the previous screen.
- 5 Press the \rightarrow arrow once to return to the previous menu, or press the \rightarrow arrow repeatedly until the OSD closes.

OSD Options

You can adjust the following OSD options:

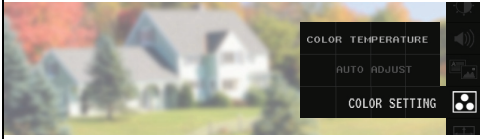
OSD Option	Description
AUTO ADJUST	Automatically adjusts your monitor for the optimal settings. (VGA input only)
LUMINANCE	BRIGHTNESS —Adjusts the luminance level of the screen. CONTRAST —Adjusts the contrast level of the screen. DCR —Displays a high dynamic contrast ratio.
AUDIO ADJUST	Adjusts the volume.

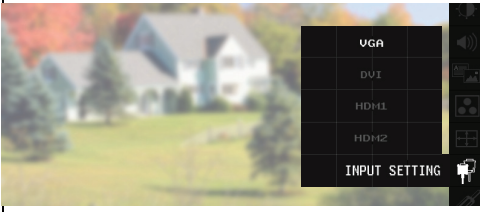

OSD Option	Description
<p>THEME MODE</p> 	<p>Lets you select a display mode. You can select GENERAL, PICTURE, MOVIE, or GAME.</p>
<p>COLOR SETTING</p> 	<p>COLOR TEMPERATURE—Adjusts the screen color. A high color temperature has more blue. A low color temperature has more red and yellow. AUTO ADJUST—Automatically adjusts the color for the best image.</p>
<p>SCREEN SETTING</p> 	<p>VERTICAL POSITION—Moves the screen image up or down. HORIZONTAL POSITION—Moves the screen image right or left. CLOCK—Adjusts your monitor’s internal sampling clock rate. PHASE—Adjusts your monitor’s internal signal phase.</p>
<p>INPUT</p> 	<p>ANALOG—Sets the video input to analog. If the video input signal is from an analog device, select this option. DIGITAL—Sets the video input to digital. If the video input signal is from a digital device, select this option.</p>
<p>SYSTEM</p> 	<p>POWER SAVING—Selects the power-saving mode. You can select:</p> <ul style="list-style-type: none"> STANDARD—Meets the EPA Energy Star power management standards. When you turn your monitor on or off or it goes into or comes out of standby mode, your monitor turns the image on or off immediately. ADVANCED—Extends the life of the backlights by slowly dimming or brightening the image when you turn your monitor off or on or when it goes into or comes out of standby mode. <p>We recommend that you set this option to ON. DDC/CI—(Display Data Channel/Command Interface) Turns the DDC/CI function ON or OFF.</p>



Maintaining and Troubleshooting

Maintaining

Warning:

To avoid the risk of electric shock or damage to your monitor, make sure that the power cable is unplugged before cleaning your monitor.

Caution:

Do not use volatile solvents (such as toluene, rosin, alcohol, or benzine) to clean your monitor. These types of chemicals can damage the case or screen.

Cleaning the case

To clean the case:

- 1 Use a soft cloth moistened with a diluted, neutral cleaner (like a liquid dish soap) to wipe the case. Make sure that you wring liquid out of the cloth before you wipe to prevent liquid from dripping into the case.
- 2 Wipe the case with a dry cloth.

Cleaning the screen

Caution:

The screen glass is fragile and can easily break. Do not scrape the screen with a sharp object. Do not press or tap on the screen.

To clean the screen:

- 1 Use a soft cloth moistened with a diluted neutral cleaner (like a liquid dish soap) to wipe the screen. Make sure that you wring liquid out of the cloth before you wipe to prevent liquid from dripping into the case.
- 2 Wipe the screen with a dry cloth.

Troubleshooting

If your monitor fails or the performance changes dramatically, check the following troubleshooting instructions. If your monitor still fails to perform as expected, contact the VIZIO for assistance by calling **(877)-698-4946** or e-mail us at **techsupport@vizio.com**.

Problem	Solution
No power	<ul style="list-style-type: none"> • Make sure that your monitor is turned on. • Make sure that the power cord is securely connected to the power outlet. • Plug another electrical device (like a radio) into the power outlet to make sure that the outlet is supplying power.
Power is on, but the screen is black	<ul style="list-style-type: none"> • Make sure that the video cable is connected correctly and securely. • Make sure that the connected video device is turned on. • Adjust brightness and contrast. • Move the mouse or press a keyboard key to make sure that the computer is not in sleep mode.



Problem	Solution
Wrong or abnormal colors appear	<ul style="list-style-type: none"> • If any colors (red, green, or blue) are missing, check the video cable to make sure it is securely connected and that no pins on the cable connector are bent or broken. • Adjust the color temperature by using the OSD.
You see a distorted picture	<p>You may be getting interference from electrical appliances, cars, motorcycles, or fluorescent lights.</p> <ul style="list-style-type: none"> • Try moving your monitor to a different location. • Plug your monitor into a different power outlet, preferably on a different circuit than that the interfering appliance is connected to.
Your monitor has dots that are always dark or colored	<p>Your monitor is manufactured using an extremely high level of precision technology. Sometimes some dots (pixels) on your monitor screen may not display. Pixel defects within industry specifications are inherent to this type of product and do not constitute a defective product.</p>

Email: techsupport@vizio.com

(877) 698-4946

Fax: (949) 585-9563

Hours: Monday - Friday: 6am to 9pm

Saturday - Sunday 8 am to 4pm

Address:

39 Tesla, Irvine, CA 92618

Telephone: (949) 428-2525

Fax: 949-585-9514

Web: www.vizio.com



Specifications and Regulations

Specifications

Size	25.5" diagonal
Pixel/Native resolution	1920 × 1200
Color Gamut	72%
Brightness	300 cd/m2 (typical)
Pixel Pitch (mm)	0.2865 × 0.2865
Number of Colors	16.7 million (6b Bit +Hi-FRC)
Response Time	5 ms (typical)
Response Time with OD Open (Gray to Gray)	3 ms
Contrast Ratio	1000:1 (typical)
DCR	2000:1
Viewing Angles	Horizontal angle (L/R): 170° Vertical angle (U/D): 160°
Aspect Ratio	16:10
Monitor Surface Treatment	Covered glass and high-polish rear cover
Connections and Inputs	D-sub × 1 DVI × 1 HDMI × 2 Audio in × 1 Audio out (headphone) × 1
USB 2.0	Upstream × 1 Downstream × 4
Swivel	120° / 120°
Tilt	-5° / +20°
Height-Adjustable Range	0 mm ~ 110 mm
Speaker / Audio	Built-in (3W * 2)
OSD Languages	English, French, Spanish
Auto Key	Yes
MTBF (hours, exclude lamp)	50,000 hours
Certifications	FCC, UL/cUL, CB
Energy Star Compliant	Yes
RoHS Compliant	Yes
Security (Kensington® lock slot)	Yes
Power Consumption (each mode)	Full power: <75W Standby mode: <2W DC off mode: <1W
Power Supply Type	Built-in
Power Input	90V ~ 264V
Wall Mount Bracket	3.94 inches × 3.94 inches (100 mm × 100 mm)
Monitor Dimensions (W × H × D)	24.89 × 18.56 × 9.3 inches (632.1 × 471.5 × 236.2 mm) 24.89 × 18.56 × 4.16 inches (632.1 × 471.5 × 105.7 mm) 24.89 × 17.68 × 4.16 inches (632.1 × 449 × 105.7 mm)
Weight	Net weight without arm and stand: 21.16 lbs. (9.6 kg) Net weight with stand: 25.73 lbs. (11.67 kg) Gross weight with packaging: 32.52 lbs. (14.75 kg)
Temperature	Operating: 41° ~ 95°F (5° ~ 35°C) Storage: -4° ~ 140°F (-20° ~ 60°C)



Humidity	Operating: 20% ~ 80% Storage: 5% ~ 90%
Altitude	Operating: 12,000 feet Storage: 40,000 feet

Regulations

FCC warning

Changes or modifications not expressly approved by the party responsible for compliance with the FCC Rules could void the user's authority to operate this equipment.



Index

A

adjusting
 monitor settings 13
 screen height 11
 screen tilt 11
 adjusting screen swivel 11
 ANALOG option 14
 AUDIO ADJUST option 13
 AUTO ADJUST option 13, 14
 AUX IN port 8

B

back view 8
 BRIGHTNESS option 13

C

cleaning
 case 15
 screen 15
 COLOR SETTING options 14
 COLOR TEMPERATURE option 14
 computer
 connecting 11
 connecting
 computer 11
 DVI 11
 HDMI 11
 power cord 12
 USB devices 11
 VGA 11
 CONTRAST option 13

D

DDC/CI option 14
 DIGITAL option 14
 DVI connection 11
 DVI port 8

F

features 6
 front view 6

H

HDMI connection 11
 HDMI-1 port 8
 HDMI-2 port 7
 headphone port 7
 height
 adjusting 11
 HORIZONTAL POSITION option 14

I

INPUT options 14

L

LUMINANCE options 13

M

maintaining 15
 cleaning case 15
 cleaning screen 15
 monitor settings
 adjusting 13
 AUDIO ADJUST 13
 AUTO ADJUST 13
 COLOR SETTING 14
 INPUT 14
 LUMINANCE 13
 SCREEN SETTING 14
 SYSTEM 14
 THEME MODE 14

O

OSD options 13

P

package contents 6

ports

AUX IN 8
 DVI 8
 HDMI-1 8
 HDMI-2 7
 headphone 7
 power 8
 USB 7, 8
 power connector 8
 power cord connection 12
 POWER SAVING option 14

S

safety instructions 2
 SCREEN SETTING options 14
 setting up 8
 side view 7
 specifications 17
 stand
 attaching 8
 swivel
 adjusting 11
 SYSTEM options 14

T

THEME MODE option 14
 tilt
 adjusting 11
 troubleshooting 15
 turning on 12

U

USB connection 11
 USB ports 7, 8

V

VERTICAL POSITION option 14
 VGA connection 11
 VGA port 8

W

wall-mounting 12



VIZIO Limited Product Warranty

VIZIO provides a “ONE-YEAR LIMITED WARRANTY” against manufacturing defects in materials and workmanship to the original purchaser of a new VIZIO display purchased from an authorized VIZIO U.S. reseller and used in the fifty (50) United States or Puerto Rico.

VIZIO's Responsibility

VIZIO displays purchased new from an authorized VIZIO U.S. reseller and that are used in the fifty (50) United States or Puerto Rico are warranted to be free from manufacturing defects in materials and workmanship for one (1) year from the date of the original retail purchase. If the display fails to conform to this limited warranty, VIZIO will, at its option and sole discretion, repair or replace the display.

Labor

During the one-year limited warranty period, VIZIO will provide, when needed, service labor to repair a manufacturing defect. Repairs required on displays which are thirty (30) inches and larger generally will be made “on-site” where the display is installed. The determination for performing the on-site repair is dependent upon the manufacturing defect and is at VIZIO's option and sole discretion. Repairs required on displays which are less than thirty (30) inches generally will be performed at a VIZIO service center.

Parts

Repairs may be made with new or recertified parts, or the entire unit may be replaced with a new or recertified unit, at VIZIO's option and sole discretion. Replacement parts or replacement units provided under this limited warranty are warranted for the remaining portion of the original warranty period, or for ninety (90) days from warranty service or replacement, whichever is later.

How to Obtain Warranty Service

To obtain warranty service, contact VIZIO Technical Support via email at TechSupport@VIZIO.com, via phone at 877-MYVIZIO (877-698-4946), or via postal mail at VIZIO Technical Support, 39 Tesla, Irvine, CA 92618. You must provide the model, serial number, and date of purchase. VIZIO Technical Support is available from 6:00AM to 9:00PM Pacific Time, Monday through Friday, and 10:00AM to 2:00PM Pacific Time, Saturday and Sunday. Please note that holiday hours may vary. For up to date information, please visit www.VIZIO.com.

VIZIO reserves the right to assess all warranty claims and to determine if defects or damages are covered by this limited warranty. In case of a claim that is not covered by this warranty, you will be contacted to determine whether VIZIO should repair the damage for a fee or whether the product should be returned to you as received by the service technician or service center.

Parts and service labor that are VIZIO's responsibility under this limited warranty will be provided without charge. All other service is at the customer's expense. VIZIO reserves the right to charge the customer for any service call for anything not covered by this limited warranty. Before you ask for warranty service, please review your User Manual. You may avoid a service call and a service charge.

Please refer to the reverse side of this page for additional information regarding how to obtain warranty service.

PLEASE DO NOT RETURN YOUR UNIT TO VIZIO WITHOUT PRIOR AUTHORIZATION.



Not Covered

This limited warranty does not cover the following: cosmetic defects; damage, malfunctions or failures resulting from shipping or transit, improper or faulty installation, abuse, operation contrary to furnished instructions, operation on incorrect power supplies, products not supplied by VIZIO, modification, alteration, improper servicing or tampering; damage from fire, water, lightning, power surges, abnormal environmental conditions or other acts of nature; normal wear and tear; unsatisfactory visual or audio performance not caused by a manufacturing defect; or displays with a missing or unreadable serial number. Operation of the display for commercial purposes or in applications or uses for which the display is not intended is not covered by this limited warranty. "Image Sticking", caused by static images on the screen for extended periods and or excessive brightness and contrast levels, is not covered by this limited warranty. Installation, removal, transportation and reinstallation of a display, and routine maintenance and cleaning, are not covered by this limited warranty.

THERE ARE NO EXPRESS WARRANTIES OTHER THAN THOSE LISTED OR DESCRIBED ABOVE. ANY IMPLIED WARRANTIES, INCLUDING ANY IMPLIED WARRANTY OF MERCHANTABILITY AND FITNESS FOR A PARTICULAR PURPOSE, SHALL BE LIMITED IN DURATION TO THE PERIOD OF TIME SET FORTH ABOVE. VIZIO'S TOTAL LIABILITY FOR ANY AND ALL LOSSES AND DAMAGES RESULTING FROM ANY CAUSE WHATSOEVER, INCLUDING VIZIO'S NEGLIGENCE, ALLEGED DAMAGE, OR DEFECTIVE GOODS, WHETHER SUCH DEFECTS ARE DISCOVERABLE OR LATENT, SHALL IN NO EVENT EXCEED THE PURCHASE PRICE OF THE DISPLAY. VIZIO SHALL NOT BE RESPONSIBLE FOR LOSS OF USE, COMMERCIAL LOSS, LOST REVENUE OR LOST PROFITS, OR OTHER INCIDENTAL OR CONSEQUENTIAL DAMAGES. SOME STATES DO NOT ALLOW LIMITATIONS ON HOW LONG AN IMPLIED WARRANTY LASTS OR THE EXCLUSION OR LIMITATION OF INCIDENTAL OR CONSEQUENTIAL DAMAGES, SO THE ABOVE LIMITATIONS OR EXCLUSIONS MAY NOT APPLY TO YOU.

This warranty gives you specific legal rights, and you may also have other rights, which vary from state to state. This is the only warranty applicable; no one is authorized to extend or modify it or to grant any other warranty on VIZIO's behalf.

Owner's Responsibility

To ensure warranty service, keep the dated bill or sales receipt as evidence of the purchase date and location. This limited warranty applies only to original purchaser and is non-transferable.

Note:

Warranty service conditions are subject to change. For the latest Warranty Terms and Conditions and additional information regarding VIZIO's Limited Product Warranty, please see complete details online at www.VIZIO.com.

VIZIO Return Policy

VIZIO's return policy allows for products purchased directly from VIZIO to be returned by the original purchaser during the initial thirty (30) day period following the date of purchase. A VIZIO return authorization number must first be obtained as provided below. The refund will be the purchase price actually paid by the purchaser less a ten percent (10%) restocking fee per each item returned. Shipping and handling are not refundable.

The return authorization number must first be obtained from VIZIO's Customer Service by emailing CustomerSupport@VIZIO.com or by calling 949-428-2525, 6:00AM to 9:00PM Pacific Time, Monday through Friday, and 10:00AM to 2:00PM Pacific Time, Saturday and Sunday. Please note that holiday hours may vary. For up to date information, please visit www.VIZIO.com.



Products must be returned to the address specified by VIZIO Customer Service and must be shipped in the original packaging, with freight prepaid to VIZIO, and must be received in new and unused condition. The return authorization number must be included in the packaging. VIZIO reserves the right to assess fees for any damaged or missing parts in addition to the ten percent (10%) restocking fee.

Return authorization numbers are valid for only fifteen (15) days from issuance. The customer is responsible for and must prepay all shipping charges and shall assume all risk of loss or damage to the product while in transit to VIZIO. If the product is returned to VIZIO (i) without a VIZIO return authorization number, and/or (ii) beyond the fifteen (15) day period, and/or (iii) without proper packaging, VIZIO retains the right to refuse delivery of such return or may return the unit to the customer at the customer's expense and with no refund issued. This return policy does not apply to defective products. Please read VIZIO's Limited Product Warranty for warranty terms and conditions.

On-Site Warranty Repair Procedure

On-Site Warranty Repair generally is performed on repairable displays which are 30 inches and larger.

If VIZIO Technical Support determines that a problem with a display unit may be within the terms and conditions of the VIZIO Limited Product Warranty and that an on-site repair may be performed, the customer will be provided with an on-site repair authorization number and on-site repair instructions. The determination for performing the on-site repair may be dependent upon the manufacturing defect and is at VIZIO's option and sole discretion. Proof of purchase is required to confirm the product is within the one-year limited warranty period and meets the terms and conditions of the VIZIO Limited Product Warranty.

On-site repair service is requested through VIZIO's third-party service provider. After VIZIO provides the customer with the on-site repair (OSR) authorization number, the third-party service provider will contact the customer and will schedule the repair at the customer's location. The total approximate time for the repair process, which includes the repair diagnosis, dispatching the technician, shipping the replacement part(s), and arranging the appointment with the customer, is completed within approximately 3 to 5 business days, pending availability of these factors.

If it is determined the product can not be repaired on-site, the customer will be required to ship the unit to VIZIO's service center, per the below warranty replacement procedure.

VIZIO is not responsible for the de-installation or re-installation of the product. However, some standard installation may be performed during the on-site repair, at VIZIO's option and sole discretion. Please read VIZIO's Limited Product Warranty for warranty terms and conditions.

Warranty Replacement Procedure

Warranty Replacement generally is performed on displays which are determined to be economically unrepairable.

If VIZIO Technical Support determines that a problem with a display unit may be within the terms and conditions of the VIZIO Limited Product Warranty and that a repair is not economically possible, based on certain manufacturing defects in materials and/or workmanship, and/or at VIZIO's option and sole discretion, the customer will be provided with a return authorization number and replacement instructions. Proof of purchase is required to confirm the product is within the one-year limited warranty period and meets the terms and conditions of the VIZIO Limited Product Warranty.

For displays forty-two inches (42") and larger, VIZIO will generally cover the transportation charges to perform an on-site swap of the original unit with the replacement unit. For displays under forty-two inches (42"), the customer is responsible for the transportation charges to VIZIO's service center. VIZIO will be responsible for the return transportation charges from the service center to the customer. Please read VIZIO's Limited Product Warranty for warranty terms and conditions.



Mail-In Warranty Repair Procedure

Mail-In Warranty Repair generally is performed on displays which are smaller than 30 inches.

If VIZIO Technical Support determines that a problem with a display unit may be within the terms and conditions of the VIZIO Limited Product Warranty and that a mail-in repair may be performed, the customer will be provided with a return authorization number and mail-in repair instructions. Proof of purchase is required to confirm the product is within the one-year limited warranty period and meets the terms and conditions of the VIZIO Limited Product Warranty.

The customer will be provided with instructions for packing and shipping the unit to the VIZIO service center. The original carton box and packing material, or an equivalent as designated by VIZIO, must be utilized. The cost of shipping to VIZIO's service center is at the customer's expense. After the product is repaired and tested, the VIZIO service center will ship the unit back to the customer at VIZIO's expense. VIZIO is not responsible for the de-installation or re-installation of the product. Please read VIZIO's Limited Product Warranty for warranty terms and conditions.

PLEASE DO NOT RETURN YOUR UNIT TO VIZIO WITHOUT PRIOR AUTHORIZATION.

